



ELECTRIC MOTORS, GEARMOTORS AND DRIVES

Installation, Lubrication and Maintenance Instructions LeCentric™ Inline Gear Reducers



Table of Contents

	Page No.
CAUTION/WARNING INFORMATION	
.....	2
Installation Instructions	3
Lubrication	
Lubrication Instructions	4
Lubrication Quantities	4
Approved Lubricants and Suppliers	4
General Operation	
Shaft Connections	5
Mounting Positions	5
Maintenance Instructions	6
Class of Service	6

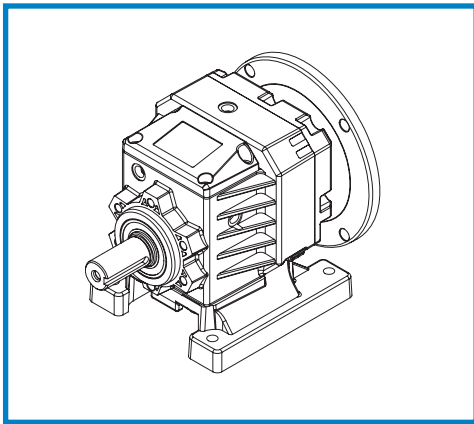
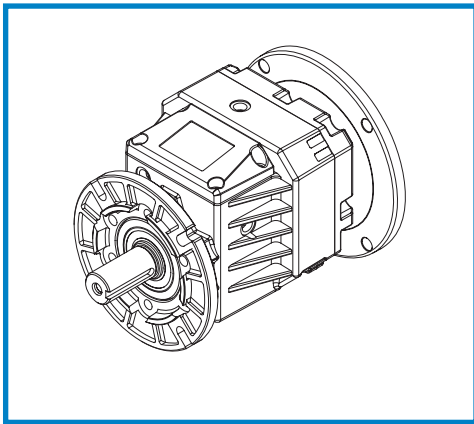



IMPORTANT INFORMATION



Please Read Carefully



The following  and  information is supplied to you for your protection and to provide you with many years of trouble free and safe operation of your LEESON product.

Read **ALL** instructions prior to operating reducer. Injury to personnel or reducer failure may be caused by improper installation, maintenance or operation.

WARNING

- Written authorization from LEESON is required to operate or use reducers in man lift or people moving devices.
- Check to make certain application does not exceed the allowable load capacities published in the current catalog.
- Buyer shall be solely responsible for determining the adequacy of the product for any and all uses to which Buyer shall apply the product. The application by Buyer shall not be subject to any implied warranty of fitness for a particular purpose.
- For safety, Buyer or User should provide protective guards over all shaft extensions and any moving apparatus mounted thereon. The User is responsible for checking all applicable safety codes in his area and providing suitable guards. Failure to do so may result in bodily injury and/or damage to equipment.
- Hot oil and reducers can cause severe burns. Use extreme care when removing lubrication plugs and vents.
- Make certain that the power supply is disconnected before attempting to service or remove any components. Lock out the power supply and tag it to prevent unexpected application power.
- Reducers are not to be considered fail safe or self-locking devices. If these features are required, a properly sized, independent holding device should be utilized. Reducers should not be used as a brake.
- Any brakes that are used in conjunction with a reducer must be sized or positioned in such a way so as to not subject the reducer to loads beyond the catalog rating.
- Lifting supports including eyebolts are to be used for vertically lifting the gearbox only and no other associated attachments or motors.
- Use of an oil with an EP additive on units with backstops may prevent proper operation of the backstop. Injury to personnel, damage to the reducer or other equipment may result.
- Overhung loads subject shaft bearings and shafts to stress which may cause premature bearing failure and or shaft breakage from bending fatigue, if not sized properly.

CAUTION

- Test run unit to verify operation. If the unit tested is a prototype, that unit must be of current production.
- If the speed reducer cannot be located in a clear and dry area with access to adequate cooling air supply, then precautions must be taken to avoid the ingestion of contaminants such as water and the reduction in cooling ability due to exterior contaminants.
- Mounting bolts should be routinely checked to ensure that the unit is firmly anchored for proper operation.

IMPORTANT INFORMATION

In the event of the resale of any of the goods, in whatever form, Resellers/Buyers will include the following language in a conspicuous place and in a conspicuous manner in a written agreement covering such sale:

The manufacturer makes no warranties or representations, express or implied, by operation of law or otherwise, as to the merchantability or fitness for a particular purpose of the goods sold hereunder. Buyer acknowledges that it alone has determined that the goods purchased hereunder will suitably meet the requirements of their intended use. In no event will the manufacturer be liable for consequential, incidental or other damages. Even if the repair or replacement remedy shall be deemed to have failed of its essential purpose under Section 2-719 of the Uniform Commercial Code, the manufacturer shall have no liability to Buyer for consequential damages.

Resellers/Buyers agree to also include this entire document including the warnings and cautions above in a conspicuous place and in a conspicuous manner in writing to instruct users on the safe usage of the product.

This information should be read together with all other printed information supplied by LEESON.



INSTRUCTIONS

General Operation

1. Run the motor which drives the reducer and check the direction of reducer output rotation. Consult motor nameplate for instructions to reverse the direction of rotation.
2. Attaching the load: On direct coupled installations, check shaft and coupling alignment between speed reducer and loading mechanism. On chain/sprocket and belt/pulley installation, locate the sprocket or pulley as close to the oil seal as possible to minimize overhung load. Check to verify that the overhung load does not exceed specifications published in the catalog.
3. High momentum loads: If coasting to a stop is undesirable, a braking mechanism should be provided to the speed reducer output or the driven mechanism.

CAUTION The system of connected rotating parts must be free from critical speed, torsional or other type vibration, no matter how induced. The responsibility for this system analysis lies with the purchaser of the speed reducer.

Installation Instructions

The following instructions apply to standard Leeson LeCentric™ type reducers with base or flange mounting in motorized and non-motorized double and triple reduction options.

1. Mount the unit to a rigid flat surface using grade 5 or higher fasteners. The mounting fasteners should be the largest standard size that will fit in the base mounting hole. Shim as required under flange or base feet which do not lie flat against the mounting surface.
2. LeCentric™ reducers are filled with proper amount of oil from LEESON. Oil quantity is based on mounting position, as indicated on reducer nameplate. Unless otherwise indicated with order, all reducers are filled to level indicated for position H3. If position other than the one indicated on nameplate is required, refer to Figure 1 for alternate mounting positions and Table 1 for oil quantities.
3. Connect motor to speed reducer.
4. LeCentric™ reducers are designed to operate without a vent. Installation of a vent is not required.

CAUTION DO NOT CHANGE MOUNTING POSITIONS WITHOUT CONTACTING FACTORY. Altering the mounting position may require special lubrication provisions which must be factory installed.

CAUTION Do not operate the reducer without making sure it contains the correct amount of oil. Confirm that mounting position on nameplate matches application requirement per Figure 1. Do not overfill or underfill with oil, or injury to personnel, reducer or other equipment may result.

CAUTION A unit cannot be used as an integral part of a machine superstructure which would impose additional loads on the unit other than those imposed by the torque being transmitted either through a shaft-mounted arrangement, and any shaft mounted power transmitting device. (e.g. sprockets, pulleys, couplings)

CAUTION For safe operation and to maintain the unit warranty, when changing a factory installed fastener for any reason it becomes the responsibility of the person making the change to properly account for fastener grade, thread engagement, load, tightening torque and the means of torque retention.

Lubrication

All standard reducers ordered from the factory are filled with Mobilgear® SHC 320 synthetic oil to operate within a -25 to +113°F ambient temperature range. Lubrication quantities are specified in Table 1 for various mounting positions. Prior to startup, verify that the mounting position on nameplate matches required position (see Fig. 1). LeCentric™ reducers are filled to proper amount of oil based on mounting position printed on nameplate. **All LeCentric™ Gear Reducers will be filled with oil for position “H3” unless otherwise specified.** If the ambient temperature will be outside the range for the lubricant installed at the factory, drain and refill the reducer with the proper viscosity lubricant prior to use. Consult the factory for alternate lubricants.

Change Intervals: LeCentric™ units utilize extreme pressure lubricants which protect the teeth in the event of the oil thinning out due to local temperature rise, or high pressure due to accidental overloads. LeCentric™ reducers are “lubed-for-life” and do not require regular oil changes under normal industrial operating conditions and environments if the reducers are operated in severe environments (i.e. high or low temperatures, high altitudes) oil changes may be required. Table 2 lists approved lubricants and suppliers, for normal conditions of duty and ambient temperatures. High ambient temperatures cause the oil to thin out and reduce its protective qualities. In such cases it will be necessary to utilize heavier grades than shown. Conversely, low temperatures will necessitate a thinner grade, otherwise trouble may be experienced with burning out of motors at starting. In this condition, the pour point of the oil must be less than the lowest ambient temperature to be encountered.

CAUTION In the Food and Drug Industry (including animal food), consult the lubrication supplier for recommendation of lubricants which are acceptable to the Food and Drug Administration and/or other authoritative bodies having jurisdiction.

CAUTION Do not mix different oils in the reducer. Oils should be compatible with Viton® seal material.

CAUTION Oil should be changed/checked if reducer is used in severe environment.

CAUTION SYNTHETIC LUBRICANTS IN FOOD PROCESSING INDUSTRY Synthetic lubricants may contain toxic substances and should not be used in the food processing industry without the lubricant manufacturer’s approval. Lubricants which meet USDA “H1” classification are suitable for food processing applications.

Table 1 - Lubrication Quantities (ounces)

Series	Mounting Positions					
	H3	H6	H7	H8	V5	V6
717 (2 Stage)	8.5	10.0	13.5	13.5	13.5	17.0
717 (3 Stage)	10.0	12.0	15.0	15.0	15.0	18.5
727 (2 Stage)	8.5	10.0	13.5	13.5	13.5	17.0
727 (3 Stage)	10.0	12.0	15.0	15.0	15.0	18.5
747 (2 Stage)	15.0	19.0	34.0	37.0	37.0	39.0
747 (3 Stage)	25.5	25.5	35.5	39.0	40.5	40.5
757 (2 Stage)	19.0	29.0	37.0	40.5	40.5	42.0
757 (3 Stage)	25.5	30.5	39.0	42.0	44.0	46.0

16 oz.	=	1 Pint
2 Pints	=	1 Quart
4 Quarts	=	1 Gallon
1 Gallon	=	128 oz.

Table 2 - Approved Lubricants and Suppliers

Manufacturer	Lubricant	Temperature Range (°F)
Exxon Co. USA	Spartan Synthetic EP 320	-25 to +113
Mobil Oil Corp.	Mobilgear SHC 320	-25 to +113
Pennzoil Prod. Co.	Super Maxol “S” 320	-25 to +113

Shaft Connections

WARNING provide suitable guards in accordance with OSHA standards.

Input and output shaft extension diameter tolerance is +0.000"; -0.001" for shafts up to 1.375" diameter. The fitted component must be machined to ensure proper fit.

DO NOT drive coupling hub, pinion, sprocket or pulley on the shaft. An endwise blow on the shaft may damage gears and bearings. Coupling hubs, pinions, sprockets or pulleys must be pushed onto the shaft using a screw jack device fitted into the threaded hole provided in the end of the shaft, see Table 3 below.

Table 3 - Shaft End threaded Holes - Inches

Drive Size	Output Shaft		Input Shaft	
	Tap Size	Depth	Tap Size	Depth
717	1/4-20	.62	1/4-20	.62
727	5/16-18	.75	1/4-20	.62
747	5/16-18	.75	5/16-18	.75
757	5/16-18	.75	5/16-18	.75

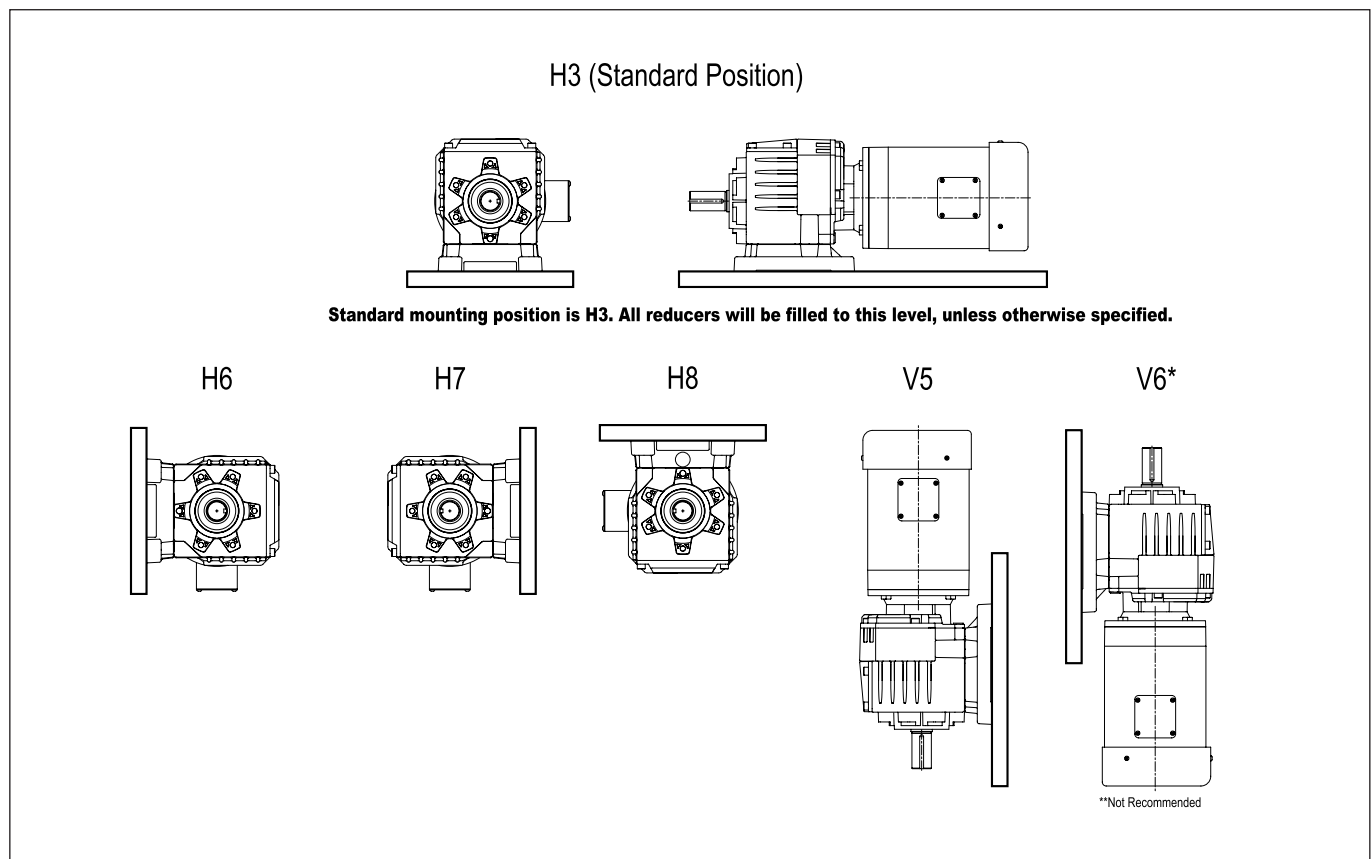

Figure 1 - Reducer Mounting Positions

Maintenance Instructions

Your LEESON reducer has been tested and adjusted at the factory. Dismantling or replacement of components must be done by LEESON to maintain the warranty.

LeCentric™ reducers are lubed-for-life and do not require regularly scheduled oil changes/checks. However, if the reducer is used in a severe environment, it is recommended that the oil is checked or changed every 6000 hrs. or after 2 years of operation. If the oil level is low, (refer to Figure 1 for mounting positions) add proper lubrication through the filler plug.

If seal leakage has resulted in the loss of a significant amount of oil, it may be necessary to add more lubricant. For normal ambient temperature conditions, LEESON recommends Mobil type Mobilgear® SHC320 synthetic gear oil for all LeCentric™ reducers.

CAUTION Mounting bolts should be routinely checked to ensure that the unit is firmly anchored for proper operation.

Seal Replacement: The LeCentric™ line of speed reducers utilize premium quality seals which are the state-of-the-art in sealing technology. Seals are, however, a wear item and eventually need to be replaced. Replacement can be easily accomplished by following the steps below:

CAUTION 1. Lock out and tag out the reducer's power source.

CAUTION 2. Remove any load from the input and/or output shafts of the reducer prior to disconnecting any drive components.

3. Remove appropriate drive components to gain access to seal to be replaced.

4. Drain oil if seal is below oil level.

5. Remove the worn seal without damaging the shaft surface or the seal bore. This can be done by drilling a 0.062" diameter hole in the casing (being careful not to drill into the bearing behind the seal). Screw a #10 sheet metal screw into the hole and pry out the seal.

6. Clean the seal bore in housing of sealant.

7. Before installing the new seal, use electrical tape to cover any keyways on the shaft to prevent seal lip damage.

8. Grease the seal lips with bearing grease and apply a sealant to the seal bore in housing.

9. Slide the seal onto the shaft being careful not to fold the inner lip over on any shaft steps.

10. Press the seal into its bore with a sleeve that presses on the seal casing, being careful to keep the seal square in its bore.

11. Refill reducer to proper level with appropriate lubricant.

CAUTION Always check for proper oil level after filling. Do not overfill or underfill with oil, or injury to personnel, reducer or other equipment may result.

CAUTION Do not mix different oils in the reducer.

12. Reconnect any drive components disconnected in Step 3. Make sure components are properly aligned.

Class of Service

All capacity ratings are based on proper application of American Gear Manufacturers Association (AGMA) service factors as given on page 70 of the LeCentric™ Catalog. Load conditions must be within cataloged ratings published in the current LEESON Catalog (available upon request).

Warranty From LEESON Electric - Refer to 7050 catalog, pages 177-178 for warranty terms and conditions.

For information contact:



LEESON ELECTRIC
A REGAL-BELOIT COMPANY
GRAFTON, WISCONSIN 53024-0241 U.S.A.
TEL (262)377-8810 FAX (262)377-9025 www.leeson.com

