



ELECTRIC MOTORS, GEARMOTORS AND DRIVES

User's Manual

17429X.00 SERIES

MODELS:

174298.00
174299.00

PWM REGENERATIVE DC TO DC DRIVES

Table of Contents

17429X.00 Drives	IV
Regenerative Drives	V
Specifications	1
Dimensions	2
Installation	3
Mounting	3
Shielding guidelines	4
Speed adjust potentiometer	5
Logic Connections	5
Heat Sinking	7
Connections	7
Fuse	8
Wiring	9
Contactor Connections (Optional)	10
Operation	12
Before applying power	12
Startup and Shutdown	12
Starting and stopping methods	13
Automatic restart upon power restoration	13
Line starting and line stopping	13
Enable/Brake/Direction	14
Voltage follower	15
Calibration	16
MINIMUM SPEED (MIN SPD)	17
MAXIMUM SPEED (MAX SPD)	17
ACCELERATION (ACCEL)	17
DECELERATION (DECEL)	18
IR COMPENSATION (IR COMP)	18
MOTOR CURRENT LIMIT (MOTOR CL)	19

REGENERATIVE CURRENT LIMIT (REGEN CL)	19
Application Notes	22
Multiple fixed speeds	22
Adjustable speeds using potentiometers in series	23
RUN/JOG Switch	24
Troubleshooting	25
Before troubleshooting	25
Status LEDs	26

Illustrations

Figure 1. Four Quadrant Operation	V
Figure 2. 174298.00 and 174299.00 Dimensions	2
Figure 3. TB501 Connections	5
Figure 4. Speed Adjust Potentiometer	6
Figure 5. Speed Adjust Potentiometer Connections	6
Figure 6. Motor and Battery Connections	8
Figure 7. Optional Coil Connections	10
Figure 8. Optional Contactor Connections	11
Figure 9. Open Collector Input	14
Figure 10. Voltage Follower Connections	15
Figure 11. Calibration Trimpot Layout	16
Figure 12. Approximate MOTOR CL and REGEN CL Settings	20
Figure 13. Approximate MOTOR CL and REGEN CL Settings	21
Figure 14. Multiple Fixed Speeds	22
Figure 15. Adjustable Fixed Speeds Using Potentiometers in Series	23
Figure 16. RUN/JOG Switch Connection to Speed Adjust Potentiometer	24

17429X.00 Drives

Leeson's 17429X.00 Series drives are four-quadrant regenerative PWM drives for low voltage applications. These open chassis drives come with the following features:

- **PULSE WIDTH MODULATION**

Lower form factor than SCR drives (1.01 versus 1.37) throughout the motor speed range. Motor runs quieter, with greater efficiency and less maintenance.

- **FOUR QUADRANT REGENERATIVE OPERATION**

See the *Regenerative Drives* section.

- **REGENERATIVE BRAKING**

No contactors required. No electromechanical components to overheat or wear out.

- **ENABLE / BRAKE / DIRECTION TERMINALS**

Choose a function by simply opening or closing a dry contact or through an open collector transistor.

- **STATUS LEDs**

Power and Fault LEDs provide a visual status of the drive.

- **OVER TEMPERATURE PROTECTION**

Drive will fold the output power back to prevent from overheating. Drive will fault if it still remains too hot.

- **MICROPROCESSOR BASED**

Allows for factory programming of 17429X.00 drives for custom drives designed for OEMs.

Regenerative Drives

Most non-regenerative variable-speed DC drives control current flow to a motor in one direction. The direction of current flow is the same direction as the motor rotation. Non-regenerative drives operate in Quadrant 1, and also in Quadrant 3 if the drive is reversible (See Figure 1).

Motors must stop before reversing direction. Unless dynamic braking is used, non-regenerative drives cannot decelerate a load faster than coasting to a lower speed.

Regenerative drives operate in two additional quadrants: Quadrant 2 and Quadrant 4. In these quadrants, motor torque is in the opposite direction of motor rotation. This allows regenerative drives to reverse a motor without contactors or switches, to control an overhauling load, and to decelerate a load faster than it would take to coast to a lower speed.

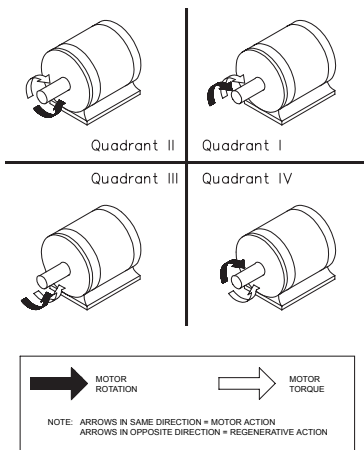

Figure 1. Four Quadrant Operation

Specifications

MODEL	MAX ARMATURE CURRENT (AMPS DC)	1 MIN. PEAK ARMATURE CURRENT (AMPS DC)	MAX ARMATURE VOLTAGE (VDC)	DC INPUT VOLTAGE RANGE (VDC)
174298.00	120*	250	12 or 24 ¹	10 - 32
174299.00	100**	240	36 or 48 ¹	20 - 62
Acceleration Time Range				0.2 - 20 seconds
Deceleration Time Range				0.2 - 20 seconds
Analog Input Voltage Range (Signal Common must be same as battery common)				0 - 5 VDC
Input Impedance (S1 to S2)				520 K
Speed Regulation				1%
Speed Range				100:1
Form Factor				1.01
Ambient Operating Temperature Range				0° C - 40° C
Weight				
174298.00				2.25 lbs
174299.00				2.25 lbs
Vibration				0.5G max (0 - 50 Hz) 0.1G max (>50 Hz)

* Derate by 15% when mounted horizontally.

** Derate by 20% when mounted horizontally.

¹ 0 - 100% of Input Voltage.

Dimensions

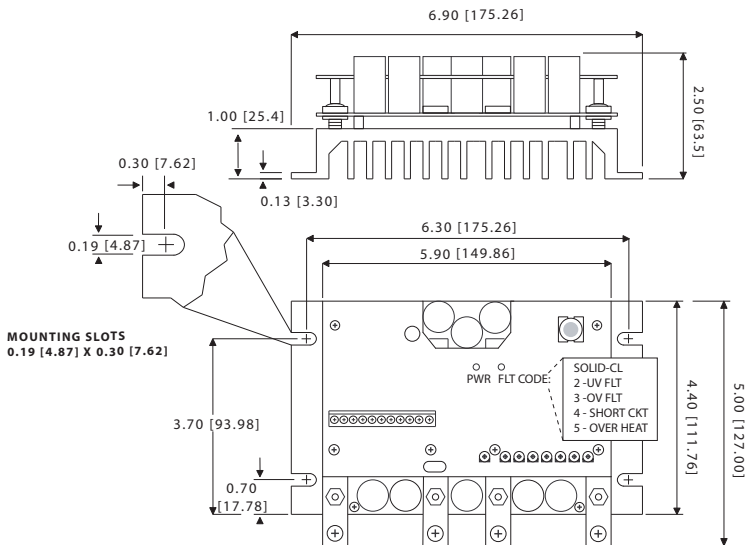

Figure 2. 174298.00 and 174299.00 Dimensions

Installation

Mounting



WARNING

Do not install, rewire, or remove this control with input power applied. Doing so may cause damage or serious injury. Make sure you have read and understood the **Safety Warnings** section before attempting installation.

- Drive components are sensitive to electrostatic fields. Avoid contact with the circuit board directly. Hold drive by the chassis only.
- Protect the drive from dirt, moisture, and accidental contact.
- Provide sufficient room for access to the terminal block and calibration trimpots.
- Mount the drive away from other heat sources. Operate the drive within the specified ambient operating temperature range.
- Keep 2" of clearance on each side of the drive and 4" of clearance above and below the drive.
- Prevent loose connections by avoiding excessive vibration of the drive.
- Mount drive with its heat sink in a vertical plane. Four 0.19 in. (5 mm) wide slots in the chassis accept #8 pan head screws. If heat sink is mounted horizontally then derate the drive as specified in **Specifications** section.

Shielding guidelines



WARNING

Under no circumstances should power and logic leads be bundled together. Induced voltage can cause unpredictable behavior in any electronic device, including motor controls.

As a general rule, Leeson recommends shielding of all conductors.

If it is not practical to shield power conductors, Leeson recommends shielding all logic-level leads. If shielding of logic level leads is not practical, the user should twist all logic leads with themselves to minimize induced noise.

It may be necessary to earth ground the shield at the drive end. If noise is generated by a device on the drive, ground the shield at the end away from the drive. Do not ground both ends of the shield.

If the drive continues to pick up noise after grounding the shield then mount the drive in a less noisy environment.

Logic wires from other input devices, such as motion controllers and PLL velocity controllers, must be separated from power lines in the same manner as the logic I/O on this drive.

Speed adjust potentiometer



WARNING

Be sure that the potentiometer tabs do not make contact with the potentiometer enclosure.

Mount the speed adjust potentiometer through a 0.38 in. (10 mm) hole with the hardware provided (see Figure 4). Install the circular insulating disk between the panel and the 10K ohm speed adjust potentiometer.

Twist the speed adjust potentiometer wire to avoid picking up unwanted electrical noise. If speed adjust potentiometer wires are longer than 18 in. (457 mm), use shielded cable. Keep speed adjust potentiometer wires separate from power leads (BAT +, BAT -, A1, A2).

Logic Connections

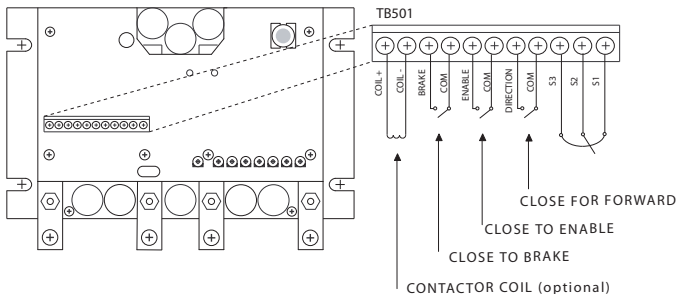

Figure 3. TB501 Connections

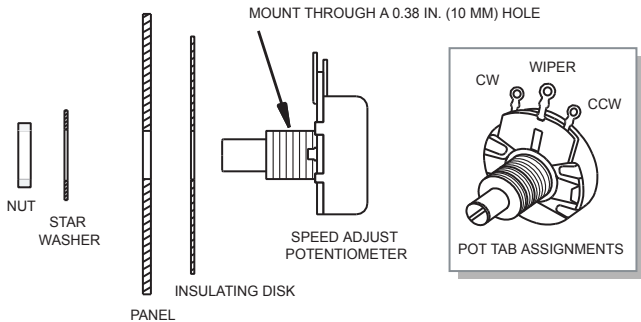

Figure 4. Speed Adjust Potentiometer

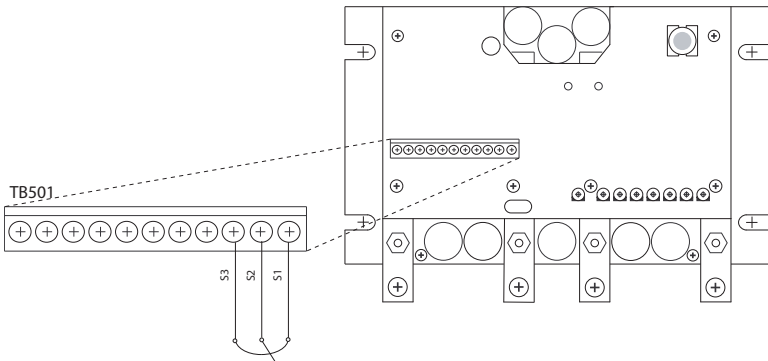

Figure 5. Speed Adjust Potentiometer Connections

Heat Sinking

174298.00 and 174299.00 drives are pre-mounted on a heat sink. For optimum heat transfer, mount the drive with heat sink fins standing vertically.

Connections



WARNING

Do not initially connect this equipment with power applied. Failure to heed this directive may result in damage or serious injury.

Leeson strongly recommends the installation of a master power switch in the voltage input line, as shown in Figure 6. The switch contacts should be rated at a minimum of 150-200% of motor nameplate current and 150% of the input voltage.

Motor

Leeson drives supply motor voltage from A1 and A2 terminals. It is assumed throughout this manual that, when A1 is positive with respect to A2, the motor will rotate clockwise (CW) while looking at the output shaft protruding from the front of the motor. If this is opposite of the desired rotation, simply reverse the wiring of A1 and A2, or close the direction terminals on TB501.

Connect a DC motor to terminals A1 and A2 as shown in Figure 6. Ensure that the motor voltage rating is consistent with the drive's output voltage.

Power Input



WARNING

This drive is not diode-protected from reverse battery voltage. You must assure that POS (+) is wired to BAT+ and NEG (-) is wired to BAT-.

Connect the DC power leads to terminals BAT+ and BAT-, or to a single-throw, single-pole master power switch as shown in Figure 6 (recommended).

Fuse

Wire a power input fuse between the stop switch (if installed) and the BAT+ terminal on the circuit board. The fuse should be rated at 150% of input voltage and 150 - 200% of maximum motor name-plate current. An example of a fuse we recommend would be Cooper Bussmann AMG-125, AMG-150, AMG-175, or AMG-200.

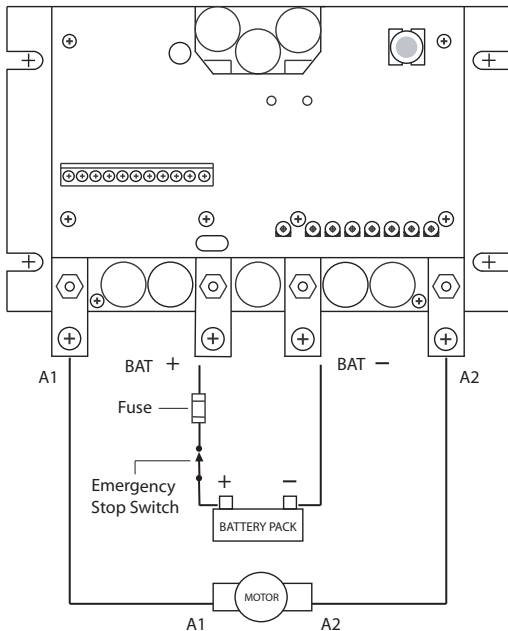

Figure 6. Motor and Battery Connections

Wiring



WARNING

Do not install, remove, or rewire this equipment with power applied. Failure to heed this warning may result in damage, explosion, or serious injury.

To prevent the risk of injury or fatality, avoid direct contact with the printed circuit board or with circuit elements.

Do not disconnect any of the motor leads from the drive unless power is removed. Opening any one motor lead may destroy the drive.

This drive is not diode-protected from reverse battery voltage. You must assure that POS (+) is wired to BAT+ and NEG(-) is wired to BAT-.

Use 18 AWG wire for speed adjust potentiometer wiring.

Size the DC voltage input and motor wire according to the following chart:

Table 1. Wire Gauge / Length Chart

Maximum Wire Length (feet)	Wire Gauge (AWG)	Armature Current (amps)
8	14	0 - 19
10	10	20 - 32
10	8	60
10	6	80
10	4	100
10	3	120

Contactor Connections (Optional)

A contactor may be connected between the battery and the drive as shown in Figure 8. The contactor and precharge circuit allow the drive to be soft charged which helps prevent sparking when the battery is being connected to the drive. Another advantage of using the contactor is that it serves as an additional safety device to protect against a run away condition, some cases of reverse polarity battery connection, and excessive charging voltages.

Once the drive is enabled, the coil output will energize and the contactor will close. The contactor's coil voltage must be the same voltage rating as the battery supply to the drive. The COIL+ can source up to 1 Amp. See Figures 7 and 8 for wiring information. An example of a contactor we recommend would be White Rogers 586 or 124 type.

Leave COIL+ and COIL- open if a contactor is not used. **DO NOT** place a jumper across COIL+ and COIL-, doing so will damage the drive.

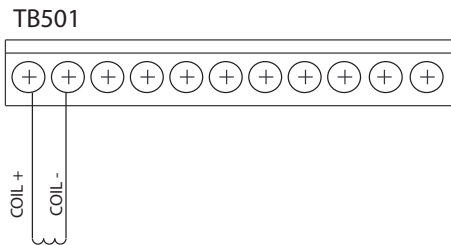

Main Contactor Coil
(optional)

Figure 7. Optional Coil Connections

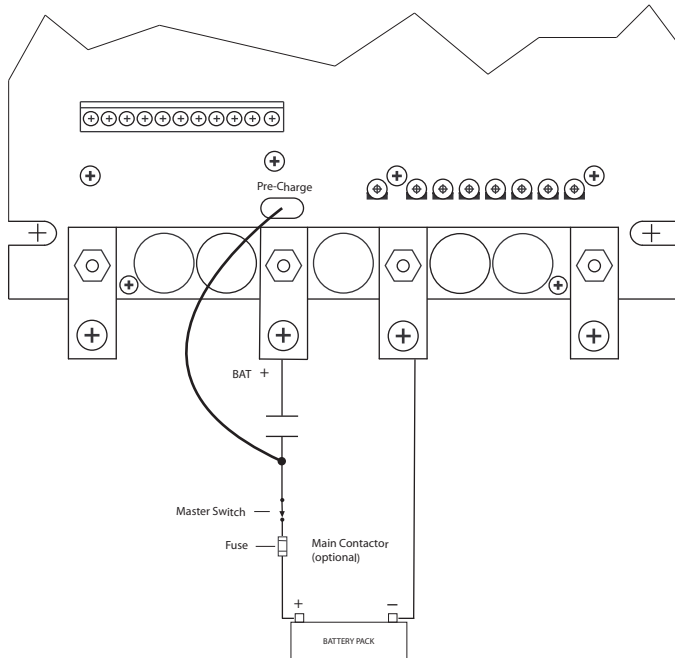

Figure 8. Optional Contactor Connections

Operation



WARNING

Dangerous voltages exist on the drive when it is powered, and up to 60 seconds after power is removed and the motor stops. **BE ALERT**. High current can cause serious or fatal injury. For your safety, use personal protective equipment (PPE) when operating this drive.

Before applying power

- Verify that no foreign conductive material is present on the printed circuit board.
- Verify battery pack connections to the drive. Check for proper polarity. Incorrect polarity will damage the drive.

Startup and Shutdown

To start the drive:

1. Turn the speed adjust potentiometer full counter-clockwise (CCW) or set the voltage signal to zero.
2. Open the brake, enable and direction switches.
3. Apply DC power to (BAT +) and (BAT -) then close the enable switch.
4. Slowly advance the speed adjust potentiometer clockwise (CW), or increase the voltage signal.

The motor slowly accelerates as the potentiometer is turned CW or the signal is increased.

Continue until the desired motor voltage is reached.

5. Close the direction switch to change motor direction.
6. Open the ENABLE to coast the motor to a stop. To brake the motor to a stop, close the brake switch while the drive is powered.

If the motor or drive do not perform as described, disconnect the DC voltage input immediately. Refer to the **Troubleshooting** section for further assistance.

Starting and stopping methods



WARNING

Decelerating to minimum speed, braking or coasting to a stop is recommended for frequent starts and stops. Do not use any of these methods for emergency stopping. They may not stop a drive that is malfunctioning. Removing the DC power to the drive is the only acceptable method for emergency stopping.

Frequent decelerating to minimum speed produces high torque. This may cause damage to motors, especially gear motors that are not properly sized for the application.

Automatic restart upon power restoration

If the enable switch is closed all drives will automatically run to set speed when power is applied.

Line starting and line stopping

Line starting and line stopping (applying and removing DC voltage input) is recommended for infrequent starting and stopping of a drive only. When DC voltage input is applied to the drive, the motor accelerates to the speed set by the speed adjust potentiometer. When DC voltage input is removed, the motor coasts to a stop.

Enable/Brake/Direction

Enable

Close the enable to allow the motor to run at the speed set by the speed pot or input signal.

Brake

Close the brake terminals to brake the motor to the speed set by the MIN SPD trimpot. The amount of time the drive takes to brake the motor to MIN SPD is determined by the DECEL trimpot. The amount of braking Torque used to stop the motor is set by the REGEN CL trimpot. MIN SPD is typically set to zero speed.

Direction

Close the direction terminals to change the motor direction.

Note: In addition to dry contact inputs, the enable, brake and direction function also accept open collector inputs. Rated at 0.5 mA or greater. See Figure 9.

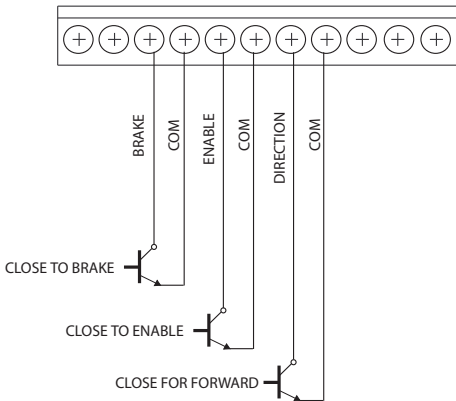

Figure 9. Open Collector Input

Voltage follower

Instead of using a speed adjust potentiometer, the drive may be wired to follow a 0 - 5 VDC signal (Figure 10). Connect the signal input (+) to S2. Connect the signal common (-) to S1. Make no connection to S3. A potentiometer can be used as a voltage divider to scale the analog input voltage. The analog signal common must be the same common as the battery common connected to BAT-. It is acceptable to connect the negative side of the battery to Earth ground in some applications.

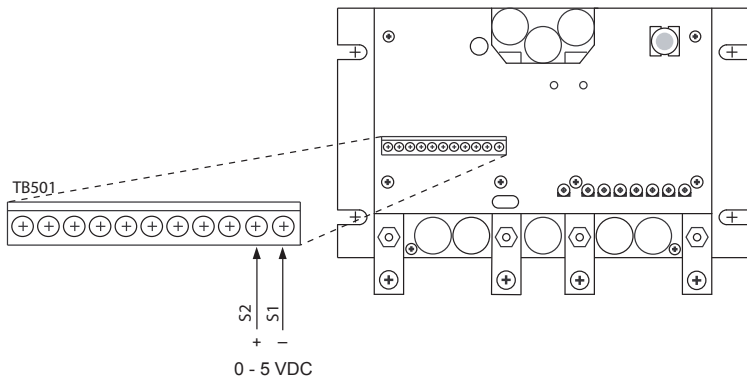

Figure 10. Voltage Follower Connections

Calibration



WARNING

Dangerous voltages exist on the drive when it is powered, and up to 60 seconds after power is removed and the motor stops. When possible, disconnect the voltage input from the drive before adjusting the trimpots. If the trimpots must be adjusted with power applied, use insulated tools and the appropriate personal protection equipment. **BE ALERT.** High current can cause serious or fatal injury.

Each drive is factory calibrated to its maximum armature voltage. The 174298.00 is factory calibrated at 170A. The 174298.00 is factory calibrated at 200A. Readjust the calibration trimpot settings to accommodate a motor with a lower armature voltage and current rating.

All adjustments increase with clockwise rotation (CW), and decrease with counter-clockwise rotation (CCW). Use a nonmetallic screwdriver for calibration. Each trimpot is identified on the printed circuit board (see Figure 11).

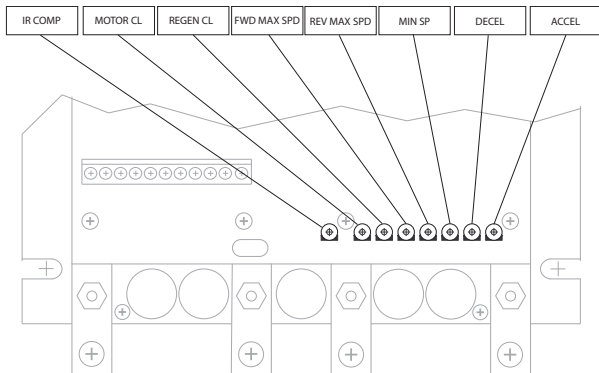

Figure 11. Calibration Trimpot Layout

MINIMUM SPEED (MIN SPD)

The MIN SPD setting determines the motor speed when the speed adjust potentiometer is turned full CCW or when the BRAKE is closed. It is factory set for zero speed.

To Calibrate MIN SPD:

1. Close the BRAKE terminals.
2. Turn the MIN SPD trimpot clock-wise until the desired motor speed is reached (usually zero).

MAXIMUM SPEED (MAX SPD)

The MAX SPD setting determines the motor speed when the speed adjust potentiometer is turned full CW. It is factory set for maximum rated speed.

To Calibrate MAX SPD:

1. Set the MAX SPD trimpot full CCW.
2. Apply power to the drive and turn the speed adjust potentiometer full CW. If an input voltage signal is used instead of a speed adjust pot, set the input signal to maximum.
3. Adjust the MAX SPD trimpot until the desired maximum motor speed is reached.

ACCELERATION (ACCEL)

The ACCEL setting determines the time the motor takes to accelerate to a higher speed. See **Specifications** for approximate accelerating times. The ACCEL setting is factory set to its minimum value (full CCW).

To Calibrate ACCEL:

1. Set the ACCEL trimpot full CCW.
2. Apply power to the drive and turn the main speed adjust potentiometer full CW. If an input voltage signal is used instead of a speed adjust pot, set the input signal to maximum. Note the time that the drive takes to accelerate to the desired speed.
3. Adjust the ACCEL trimpot until the desired acceleration time is reached. Turn the ACCEL trimpot CW to increase the acceleration time, and CCW to decrease the acceleration time.

DECELERATION (DECEL)

The DECEL setting determines the time the motor takes to decelerate to a lower speed. See **Specifications** for approximate deceleration times. The DECEL setting is factory set to its minimum value (full CCW).

To calibrate DECEL:

1. Set the DECEL trimpot full CCW.
2. Apply power to the drive and turn the main speed adjust potentiometer from full CW to full CCW.
If an input voltage signal is used instead of a speed adjust pot, set the input signal from maximum to minimum. Note the time that the drive takes to decelerate to the desired speed.
3. Adjust the DECEL trimpot until the desired deceleration time is reached. Turn the DECEL trimpot CW to increase the deceleration time, and CCW to decrease the deceleration time.

IR COMPENSATION (IR COMP)

The IR COMP setting determines the degree to which motor speed is held constant as the motor load changes. It is factory set for no compensation.

Use the following procedure to recalibrate the IR COMP setting:

1. Set the IR COMP trimpot to minimum (full CCW).
2. Rotate the speed adjust potentiometer until the motor runs at midspeed without load (for example, 900 RPM for an 1800 RPM motor). A hand held tachometer may be used to measure motor speed.
3. Load the motor armature to its full load armature current rating. The motor should slow down.
4. While keeping the load on the motor, rotate the IR COMP trimpot until the motor runs at the speed measured in step 2. **If the motor oscillates (overcompensation), the IR COMP trimpot may be set too high (CW). Turn the IR COMP trimpot CCW to stabilize the motor.**
5. Unload the motor.

MOTOR CURRENT LIMIT (MOTOR CL)



WARNING

MOTOR CURRENT LIMIT should be set to 120% of motor nameplate current rating. Continuous operation beyond this setting may damage the motor. If you intend to operate beyond the rating, contact your Leeson representative.

The MOTOR CURRENT LIMIT setting determines the maximum armature current output of the drive.

Recalibrate the MOTOR CL setting when a lower current limit is required. Refer to the MOTOR CL settings in Figure 12 or 13, or recalibrate using the following procedure:

1. With the power disconnected from the control, connect a DC ammeter in series with the armature.
2. Set the MOTOR CL trimpot to minimum (full CCW).
3. Set the speed adjust potentiometer to maximum (full CW).
4. Carefully lock the motor armature. Be sure that the motor is firmly mounted.
5. Apply line power. The motor should be stopped.
6. Slowly adjust the MOTOR CL trimpot CW slowly until the armature current is 120% of motor rated armature current.
7. Set the speed adjust potentiometer, or input voltage to minimum.
8. Remove the power from the drive and unlock the motor shaft.
9. Remove the ammeter in series with the motor armature if it is no longer needed and re-apply power to the drive.

REGENERATIVE CURRENT LIMIT (REGEN CL)

The REGENERATIVE CURRENT LIMIT setting determines the maximum armature current available for braking. Set the REGEN CL based on the desired amount of braking.

174298.00

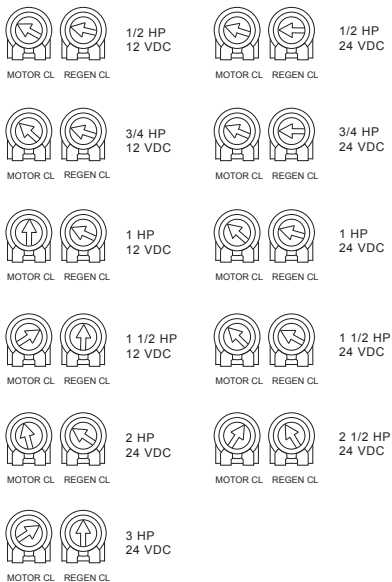

Note: The above settings are approximate. Your settings may be different due to tolerance in the drive and motor along with application requirements.

Figure 12. Approximate MOTOR CL and REGEN CL Settings

174299.00

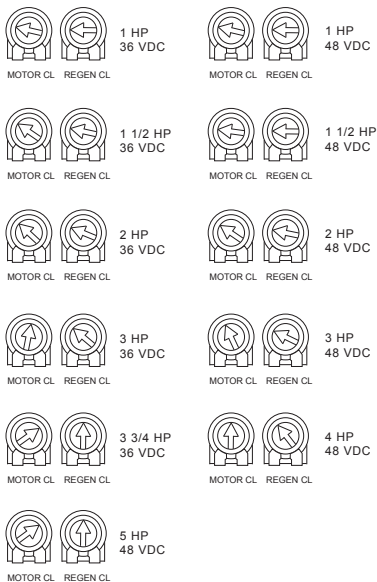

Note: The above settings are approximate. Your settings may be different due to tolerance in the drive and motor along with application requirements.

Figure 13. Approximate MOTOR CL and REGEN CL Settings

Application Notes

Multiple fixed speeds

Replace the speed adjust potentiometer with series resistors with a total series resistance of 10K ohms (Figure 14). Add a single pole, multiposition switch with the correct number of positions for the desired number of fixed speeds.

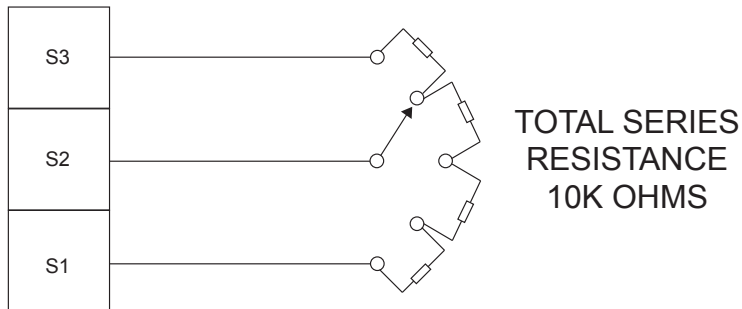

Figure 14. Multiple Fixed Speeds

Adjustable speeds using potentiometers in series

Replace the speed adjust potentiometer with a single pole, multi-position switch, and two or more potentiometers in series, with a total series resistance of 10K ohms. Figure 15 shows a connection for fixed high and low speed adjust potentiometers.

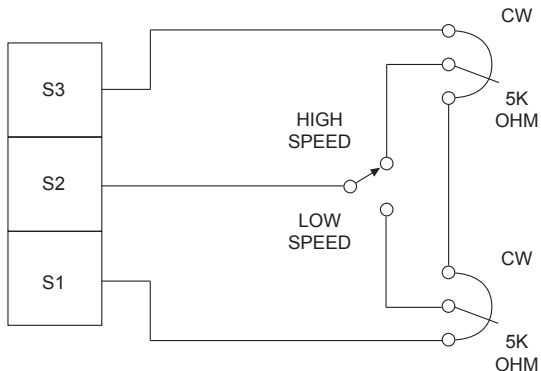

Figure 15. Adjustable Fixed Speeds Using Potentiometers in Series

RUN/JOG Switch

Using a RUN/JOG switch is recommended in applications where quick stopping is not needed and frequent jogging is required. Use a single pole, two position switch for the RUN/JOG switch, and a normally closed, momentary operated pushbutton for the JOG pushbutton (see Figure 16). When the RUN/JOG switch is set to JOG, the motor decelerates to minimum speed. Press the JOG pushbutton to jog the motor. Return the RUN/JOG switch to RUN for normal operation.

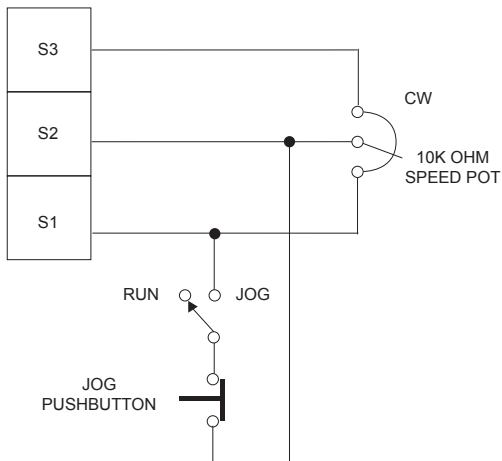

Figure 16. RUN/JOG Switch Connection to Speed Adjust Potentiometer

Troubleshooting



WARNING

Dangerous voltages and currents exist on the drive when it is powered, and up to 60 seconds after power is removed and the motor stops. When possible, disconnect the drive while troubleshooting. High current can cause serious or fatal injury.

Before troubleshooting

Perform the following steps before starting any procedure in this section:

1. Disconnect DC voltage input from the drive.
2. Check the drive closely for damaged components.
3. Check that no foreign conductive material has become lodged on the printed circuit board.
4. Verify that all connections are correct and in good condition.
5. Verify that there are no short circuits or grounded connections.
6. Check that the drive's rated armature voltage and current is consistent with the motor ratings.
7. Verify that input voltage (battery) is within specified range.

For additional assistance, contact your local Leeson distributor.

Status LEDs

Power LED

Green LED lights up when power is applied to the drive.

Fault Code LED

Provides a visual representation of the cause of a fault. Faults 2 - 5 require either the Enable or battery voltage to be cycled in order to clear the fault.

- Solid ON - Current Limit
- 2 Blinks - Under Voltage fault¹
- 3 Blinks - Over Voltage fault²
- 4 Blinks - Short circuit on output
- 5 Blinks - Over Temperature Fault

Over Temperature current fold back/trip:

If the drive heats up because it is overloaded or it is in an undersized enclosure, the drive will scale back the current limit in an attempt to lower the temperature. If the temperature isn't reduced after a period of time, the drive will trip.

¹ Under Voltage fault set at 7.5 VDC for the 174298.00 and at 16 VDC for the 174299.00

² Over Voltage fault set at 30.5 VDC for the 174298.00 and at 62 VDC for the 174299.00.

Symptom	Possible Causes	Suggested Solutions
Line fuse blows	<p>Line fuses are the wrong size.</p> <p>Motor cable or armature is shorted to ground.</p> <p>Nuisance tripping caused by a combination of ambient conditions and high-current spikes.</p> <p>Damaged Drive</p>	<p>Check that line fuses are the correct size.</p> <p>Check motor cable and armature for shorts.</p> <p>Add a blower to cool the drive components; decrease MOTOR CL settings, or resize motor and drive for actual load demand, or check for incorrectly aligned mechanical components for "jams". See the Calibration section for information on adjusting the MOTOR CL trimpot.</p> <p>Contact Leeson Drives Distributor</p>
Line fuse does not blow, but the motor does not run.	<p>Speed adjust pot or reference voltage is set to zero speed.</p> <p>MAX SPD pot is set to zero.</p> <p>Speed adjust pot or reference voltage connections are open.</p> <p>Drive is overloaded.</p> <p>Drive is not receiving DC line voltage.</p> <p>Motor is not connected.</p> <p>Brake terminals are closed or ENABLE is open.</p>	<p>Increase speed adjust pot or reference voltage setting.</p> <p>Increase MAX SPD pot.</p> <p>Check that the speed adjust pot or reference voltage connections are not open.</p> <p>Verify that the motor is not jammed. Increase MOTOR CL setting.</p> <p>Apply DC line voltage to BAT + and BAT -. Confirm power LED is illuminated.</p> <p>Connect motor to A1 and A2.</p> <p>Open the BRAKE or close the ENABLE.</p>

Symptom	Possible Causes	Suggested Solutions
Motor runs too fast at maximum speed setting or minimum speed setting.	MIN SPD and MAX SPD settings are too high.	Recalibrate MIN SPD and MAX SPD.
Motor will not reach the desired speed.	<p>Battery voltage too low.</p> <p>MAX SPD setting is too low.</p> <p>IR COMP setting is too low.</p> <p>Motor is overloaded.</p> <p>Drive is reaching over temperature trip.</p>	<p>Charge batteries.</p> <p>Increase MAX SPD setting.</p> <p>Increase IR COMP setting.</p> <p>Check motor load. Resize the motor and drive if necessary. Check red fault LED status.</p> <p>Check motor load. Resize the motor or enclosure.</p>
Motor pulsates or surges under load.	<p>IR COMP is set too high.</p> <p>Control is in current limit mode.</p>	<p>Adjust the IR COMP setting slightly CCW until the motor speed stabilizes.</p> <p>Check that motor and drive are of sufficient horsepower and current rating.</p>



ELECTRIC MOTORS, GEARMOTORS AND DRIVES

2100 Washington Street Grafton, WI 53024-0241 U.S.A.

Phone: (262) 377-8810; Fax: (262) 377-3440

Document Number 250-0403, Revision 0

Printed in the U.S.A -- March 2006