



SUB-FHP AC GEARMOTORS PARALLEL SHAFT GEARMOTORS

12-100 In-Lbs
Output Torque

Design Specifications:

Single phase gearmotors, totally enclosed for continuous duty, general purpose applications.

Permanent split capacitor designs are rated for 115 VAC 60 hertz input, and have starting torques equal to the running torques. The inline gearing is of precision machined steel, with first stage steel helical gear followed by spur type gears. Lubrication is by semi-fluid grease, reducing possibility of leakage and providing permanent lubrication. Output shafts have needle bearings for high load capacities. Shafts are hardened steel.

Application Notes:

These gearmotors are designed for mounting at any angle, but shaft up with motor below should be avoided to prevent leakage of lubricant into the motor should the motor's shaft seal fail. If these gearmotors are stalled, gearhead damage may result, especially in the ratios of 60:1 and higher. Provisions to limit the torque are recommended. The torque values listed are the recommended full load torque values for reasonable gear life.

Overhung load capacities shown are at center of output shaft. All PZ Series gearmotors are supplied with continuous duty "run" capacitor. **Conduit box not supplied with motor.** See page 107 for optional conduit box.

Model PZ gearmotors have the same mounting dimensions as Bodine model D and Z gearmotors, Bison 100 gearmotors, and Baldor/Boehm PSS, plus many of the Dayton gearmotors.

For additional information, see Bulletin 1830.



PZ SERIES AC GEARMOTORS PARALLEL SHAFT • TEFC • 115V • SINGLE PHASE 40°C AMBIENT • 1.0 SERVICE FACTOR

Output RPM	F.L. Torque (Lb.In.)	Input HP	Catalog Number	Gearmotor Type & Frame	Ratio to 1	F.L. Amps 115 VAC	Over-hung Load (Lb.)	DIMENSIONS				Capacitor Mfd. 240 VAC
								P	X	XL	XH	
2	100	1/150	M1125050#	PZ5-31	900	0.4	155	3.07	3.23	8.71	7.15	3.0
9	100	1/15	M1125127	PZ4-31	180	0.9	155	3.88	3.23	10.42	8.86	10.0
19	100	1/15	M1125128	PZ4-31	90	0.9	155	3.88	3.23	10.42	8.86	10.0
28	100	1/15	M1125129	PZ3-31	60	0.9	155	3.88	2.43	9.62	8.06	10.0
57	56	1/15	M1125130	PZ3-31	30	0.9	171	3.88	2.43	9.62	8.06	10.0
94	36	1/15	M1125131	PZ3-31	18	0.9	171	3.88	2.43	9.62	8.06	10.0
142	24	1/15	M1125132	PZ2-31	12	0.9	180	3.88	2.13	9.32	7.76	10.0
283	12	1/15	M1125133	PZ2-31	6	0.9	180	3.88	2.13	9.32	7.76	10.0

TENV enclosure

▲ Use "S" discount symbol.

PZ SERIES - AC

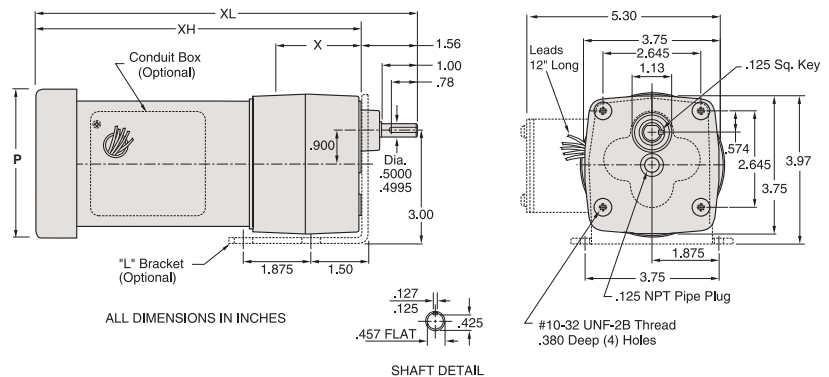

**BODINE/BISON/DAYTON
DIRECT INTERCHANGE**

QUICK REFERENCE

GEARMOTOR CROSS REFERENCE Page 163
"L" BRACKET AND CONDUIT BOX 107

25-341 In-Lbs Output Torque

Design Specifications:

Sub-FHP AC gearmotors. Totally enclosed for continuous duty, general purpose applications. All rated for 60/50 Hz operation except hi-torque single-phase which are 60 Hz only.

Gearbox has rugged aluminum die cast housing, for maximum gear and bearing support. Precision machined gearing, hardened for maximum load capability. All gearing designed and rated to AGMA Class 9 standards and to withstand momentary shock overload of 200%. Oversized output bearings for greater overhung load capacity and longer life. High-carbon alloy output shaft provides maximum strength and rigidity. All needle bearing journals are precision-ground after heat treating, to provide maximum finish and fit. Single lip, spring loaded, heavy-duty industrial oil seals help keep lubricant in and dirt out. Gears and bearings are splash lubricated with permanent, heavy-duty gear oil.

Application Notes:

These gearmotors are designed for mounting at any angle, but shaft-up with motor below gearhead is not recommended.

Run capacitor supplied with gearmotor at no additional cost. **Three phase and hi-torque single-phase models include conduit box, other single-phase models do not.** See page 107 for optional conduit box.

Overhung load capacities shown are at center of output shaft.

Model PE350 gearmotors have the same mounting dimensions as Bodine's "E" box and many Baldor/Boehm gearmotors.



PE350 SERIES AC GEARMOTORS

SINGLE PHASE • PARALLEL SHAFT • TEFC • 115/230V

60 Hz Output RPM	F.L. Torque (Lb.In.)	Input HP	Catalog Number	Type & Frame	Ratio to 1	F.L. Amps 115V AC	Overhung Load Lbs.	DIMENSIONS Inches		Capacitor Mfd. 240VAC
								XL	XH	
5	310	1/2	096000#	PE353-42	336	1.3	565	11.36	9.36	10.0
9	341	1/2	096001#	PE353-42	180	1.3	491	11.36	9.36	10.0
14	330	1/2	096002#	PE353-42	124	1.3	459	11.36	9.36	10.0
19	250	1/2	096003#	PE353-42	91	1.3	374	11.36	9.36	10.0
29	270	1/6	096004	PE353-42	58	3.2	327	13.32	11.32	15.0
34	250	1/6	096005	PE353-42	50	3.2	330	13.32	11.32	15.0
40	180	1/6	096006	PE353-42	43	3.2	303	13.32	11.32	15.0
59	135	1/6	096007	PE352-42	29	3.2	267	13.32	11.32	15.0
75	90	1/6	096008	PE352-42	23	3.2	256	13.32	11.32	15.0
113	68	1/6	096009	PE352-42	15	3.2	222	13.32	11.32	15.0
160	45	1/6	096010	PE352-42	10	3.2	196	13.32	11.32	15.0
340	25	1/6	096011	PE352-42	5	3.2	190	13.32	11.32	15.0

Hi-Torque Single Phase PE350 Gearmotors With Capacitor Start Motors

58	320	1/3	096049	PE353-42	30	7.2	300	14.56	12.56	...
85	218	1/3	096050	PE353-42	20	7.2	300	14.56	12.56	...
173	109	1/3	096051	PE353-42	10	7.2	300	14.56	12.56	...
345	55	1/3	096052	PE353-42	5	7.2	300	14.56	12.56	...

TENV enclosure

▲ Use "S" discount symbol.

**BODINE
DIRECT
INTERCHANGE**

PE350 SINGLE PHASE

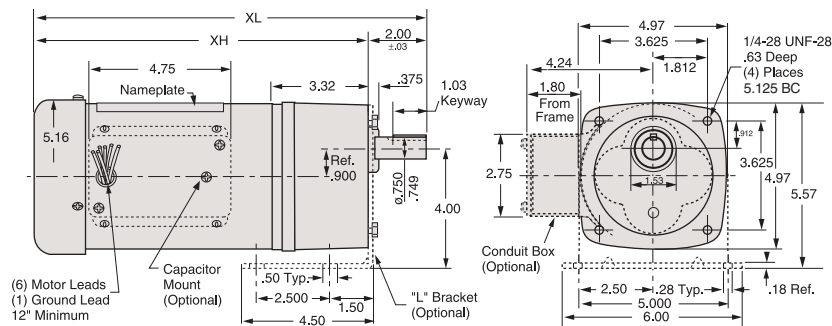

ALL DIMENSIONS IN INCHES



SUB-FHP AC GEARMOTORS PARALLEL SHAFT GEARMOTORS

25-341 In-Lbs
Output Torque

Design Specifications:

Sub-FHP AC gearmotors. Totally enclosed for continuous duty, general purpose applications. All rated for 60/50 Hz operation except hi-torque single-phase which are 60 Hz only.



Gearbox has rugged aluminum die cast housing, for maximum gear and bearing support. Precision machined gearing, hardened for maximum load capability. All gearing designed and rated to AGMA Class 9 standards and to withstand momentary shock overload of 200%. Oversized output bearings for greater overhung load capacity and longer life. High-carbon alloy output shaft provides maximum strength and rigidity. All needle bearing journals are precision-ground after heat treating, to provide maximum finish and fit. Single lip, spring loaded, heavy-duty industrial oil seals help keep lubricant in and dirt out. Gears and bearings are splash lubricated with permanent, heavy-duty gear oil.

Application Notes:

These gearmotors are designed for mounting at any angle, but shaft-up with motor below gearhead is not recommended.

Run capacitor supplied with gearmotor at no additional cost. **Three phase and hi-torque single-phase models include conduit box, other single-phase models do not.** See page 107 for optional conduit box.

Overhung load capacities shown are at center of output shaft.

Model PE350 gearmotors have the same mounting dimensions as Bodine's "E" box and many Baldor/Boehm gearmotors.



PE350 SERIES AC GEARMOTORS THREE PHASE • PARALLEL SHAFT • TEFC • 230/460V

Output RPM	F.L. Torque (Lb.In.)	Input HP	Catalog Number	Type & Frame	Ratio to 1	F.L. Amps 230V AC	Overhung Load Lbs.	DIMENSIONS XL XH Inches	
58	320	1/3	096013	PE353-42	30	1.6	300	13.81	11.81
85	218	1/3	096014	PE352-42	20	1.6	300	13.81	11.81
173	109	1/3	096015	PE352-42	10	1.6	300	13.81	11.81
345	55	1/3	096016	PE352-42	5	1.6	300	13.81	11.81

▲ Use "S" discount symbol.

PE350 THREE PHASE

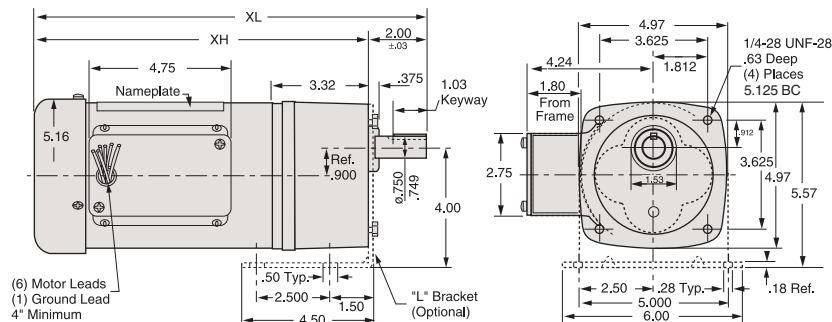

ALL DIMENSIONS IN INCHES

70-1105 In-Lbs
Output Torque

Design Specifications:

Fractional horsepower AC gearmotors. Totally enclosed for continuous duty, general purpose applications. Rated for 60 Hz input.



Gearbox has rugged aluminum die cast housing, for maximum gear and bearing support. Precision machined gearing, hardened for maximum load capability. All gearing designed and rated to AGMA Class 9 standards and to withstand momentary shock overload of 200%. Oversized output bearings for greater overhung load capacity and longer life. High-carbon alloy output shaft provides maximum strength and rigidity. All needle bearing journals are precision-ground after heat treating, to provide maximum finish and fit. Heavy-duty industrial oil seals help keep lubricant in and dirt out. Gears and bearings are splash lubricated with permanent, heavy-duty gear oil.

Application Notes:

These gearmotors are designed for mounting at any angle, but shaft-up with motor below gearhead is not recommended. P1100 AC gearmotors have the same mounting dimensions as Bison 482 gearmotors and many Dayton gearmotors. Three phase units suitable for inverter duty.

Both single and three phase models include conduit box. For additional information, see Bulletin 1830.

P1100 SERIES AC GEARMOTORS
SINGLE PHASE • FRACTIONAL HP • TEFC • 115/230V

Output RPM	F.L. Torque (Lb.In.)	Input HP	Catalog Number	Type & Frame	Ratio to 1	F.L. Amps 115V AC	Overhung Load Lbs.	DIMENSIONS XL Inches	XH
8	975	1/4	107000	P1103-48	212	5.4	700	13.42	11.92
12	1030	1/4	107004	P1103-48	143	5.4	700	13.42	11.92
18	800	1/4	107003	P1103-48	95	5.4	700	13.42	11.92
26	569	1/4	107002	P1103-48	66	5.4	650	13.42	11.92
59	248	1/4	107005	P1102-48	29	5.4	625	13.42	11.92
133	114	1/4	107001	P1102-48	13	5.4	525	13.42	11.92
18	1089	1/3	107006	P1103-48	95	6.2	700	13.67	13.17
26	752	1/3	107012	P1103-48	66	6.2	650	13.67	13.17
41	461	1/3	107011	P1102-48	42	6.2	650	13.67	13.17
59	330	1/3	107010	P1102-48	29	6.2	625	13.67	13.17
91	224	1/3	107009	P1102-48	19	6.2	575	13.67	13.17
157	125	1/3	107008	P1102-48	11	6.2	500	13.67	13.17
288	70	1/3	107007	P1102-48	6	6.2	400	13.67	13.17
22	1105	1/2	107013	P1103-48	79	8.8	700	14.17	12.67
41	700	1/2	107017	P1102-48	42	8.8	650	14.17	12.67
59	496	1/2	107016	P1102-48	29	8.8	625	14.17	12.67
91	336	1/2	107015	P1102-48	19	8.8	575	14.17	12.67
133	229	1/2	107014	P1102-48	13	8.8	525	14.17	12.67

Gearmotors

**BISON/DAYTON
DIRECT INTERCHANGE**

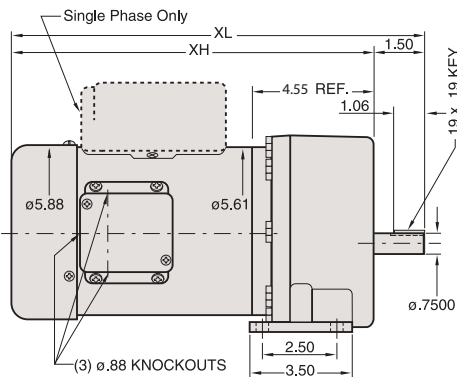
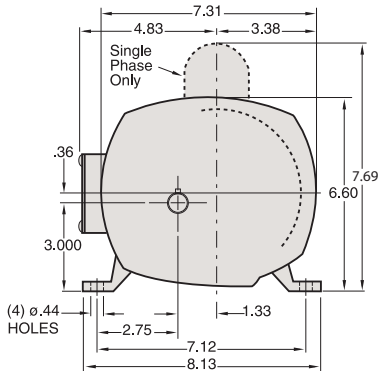

ALL DIMENSIONS IN INCHES

QUICK REFERENCE

GEARMOTOR CROSS REFERENCE Page 163
"L" BRACKET AND CONDUIT BOX 107

70-1105 In-Lbs
Output Torque

Design Specifications:

Fractional horsepower AC gearmotors. Totally enclosed for continuous duty, general purpose applications. Rated for 60 Hz input.



Gearbox has rugged aluminum die cast housing, for maximum gear and bearing support. Precision machined gearing, hardened for maximum load capability. All gearing designed and rated to AGMA Class 9 standards and to withstand momentary shock overload of 200%. Oversized output bearings for greater overhung load capacity and longer life. High-carbon alloy output shaft provides maximum strength and rigidity. All needle bearing journals are precision-ground after heat treating, to provide maximum finish and fit. Heavy-duty industrial oil seals help keep lubricant in and dirt out. Gears and bearings are splash lubricated with permanent, heavy-duty gear oil.

Application Notes:

These gearmotors are designed for mounting at any angle, but shaft-up with motor below gearhead is not recommended. P1100 AC gearmotors have the same mounting dimensions as Bison 482 gearmotors and many Dayton gearmotors. Three phase units suitable for inverter duty.

Both single and three phase models include conduit box.
For additional information, see Bulletin 1830.

**BISON/DAYTON
DIRECT INTERCHANGE**

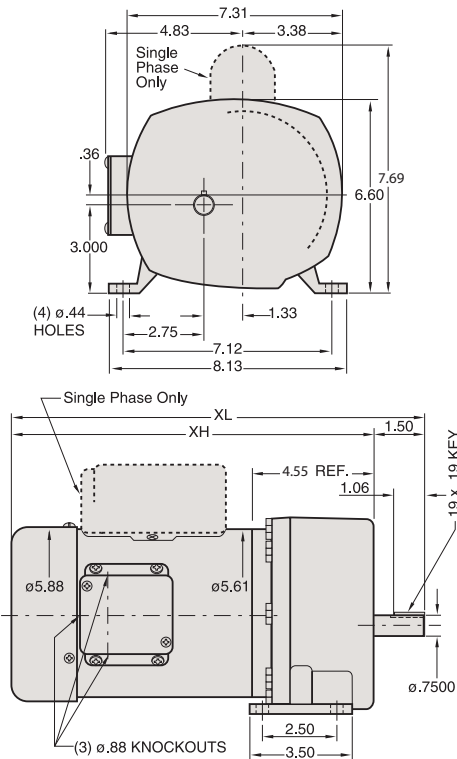

ALL DIMENSIONS IN INCHES

P1100 SERIES AC GEARMOTORS
THREE PHASE • FRACTIONAL HP • TEFC • 230/460V

Output RPM	F.L. Torque (Lb.In.)	Input HP	Catalog Number	Type & Frame	Ratio to 1	F.L. Amps 230V AC	Overhung Load Lbs.	DIMENSIONS XL XH Inches	
18	1089	1/3	107025	P1103-48	95	1.6	700	12.92	11.42
26	752	1/3	107026	P1103-48	66	1.6	650	12.92	11.42
41	461	1/3	107027	P1102-48	42	1.6	650	12.92	11.42
59	330	1/3	107028	P1102-48	29	1.6	625	12.92	11.42
91	224	1/3	107029	P1102-48	19	1.6	575	12.92	11.42
157	125	1/3	107030	P1102-48	11	1.6	500	12.92	11.42
288	70	1/3	107031	P1102-48	6	1.6	400	12.92	11.42
22	1105	1/2	107032	P1103-48	79	2.0	700	13.42	11.92
41	700	1/2	107033	P1102-48	42	2.0	650	13.42	11.92
59	496	1/2	107034	P1102-48	29	2.0	625	13.42	11.92
91	336	1/2	107035	P1102-48	19	2.0	575	13.42	11.92
133	229	1/2	107036	P1102-48	13	2.0	500	13.42	11.92
288	100	1/2	107037	P1102-48	6	2.0	400	13.42	11.92

▲ Use "S" discount symbol.

QUICK REFERENCE

GEARMOTOR CROSS REFERENCE	Page 163
"L" BRACKET AND CONDUIT BOX	107

14-113 In-Lbs
Output Torque

Design Specifications:

Single phase gearmotors, totally enclosed for continuous duty, general purpose applications. Permanent split capacitor motors rated 115/230 VAC 60/50 hertz input, and have starting torque equal to the running torque. This worm-type right-angle gearing features hardened, steel worm with bronze worm wheel for long life and quiet operation. Precision machined aluminum housings are used. Gearbox has all ball bearings. The housing is sealed and lubrication is permanent with an oil bath. The output shaft is field interchangeable from left hand style to right hand style.

Application Notes:

For optimum seal life, these right angle gearmotors have a lubrication breather positioned for horizontal mounting. For other mountings, the breather-plug must be reoriented by using a 90°/8" NPT taper pipe elbow (see drawing). However, the motor portion of the gearmotor should never be mounted below the gearhead. Overhung load capacities shown are at center of output shaft. These motors are supplied with continuous duty "run" capacity. **Conduit box not supplied with motor.** See page 107 for optional conduit box and base kit.

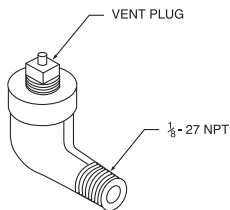

Please contact LEESON for output speeds not listed.
For additional information, see Bulletin 1830.

**BODINE/DAYTON
DIRECT INTERCHANGE**

RIGHT-ANGLE AC GEARMOTORS
TOTALLY ENCLOSED • 115/230 V • SINGLE PHASE

60 Hz Output RPM	F.L. Torque (Lb.In.)	Input HP	Catalog Number	Gearmotor Type & Frame	Ratio to 1	F.L. Amps 115V AC	Over-hung Load (Lb.)	DIMENSIONS				Capacitor Mfd.
								P Dia.	X Inches	XL	XH	
28	37	1/15	M1125080	10F60-31C	60	0.9	185	3.07	3.63	8.94	5.31	10.0+
43	34	1/15	M1125081	10F40-31C	40	0.9	185	3.07	3.63	8.94	5.31	10.0+
58	40	1/15	M1125082	10F30-31C	30	0.9	185	3.07	3.63	8.94	5.31	10.0+
85	24	1/15	M1125083	10F20-31C	20	0.9	185	3.07	3.63	8.94	5.31	10.0+
173	14	1/15	M1125084	10F10-31C	10	0.9	185	3.07	3.63	8.94	5.31	10.0+
29	110	1/6	M1145037**	13F60-38F	60	2.0	235	3.85	4.50	12.31	7.81	15.0*
43	113	1/6	M1145038**	13F40-38F	40	2.0	235	3.85	4.50	12.31	7.81	15.0*
57	95	1/6	M1145082**	13F30-38F	30	2.0	235	3.85	4.50	12.31	7.81	15.0*
83	75	1/6	M1145039**	13F20-38F	20	2.0	235	3.85	4.50	12.31	7.81	15.0*
170	43	1/6	M1145040**	13F10-38F	10	2.0	235	3.85	4.50	12.31	7.81	15.0*
340	23	1/6	M1145041**	13F05-38F	5	2.0	235	3.85	4.50	12.31	7.81	15.0*

▲ Use "S" discount symbol.
** TEFC enclosure.
+ 250 VAC
* 300 VAC

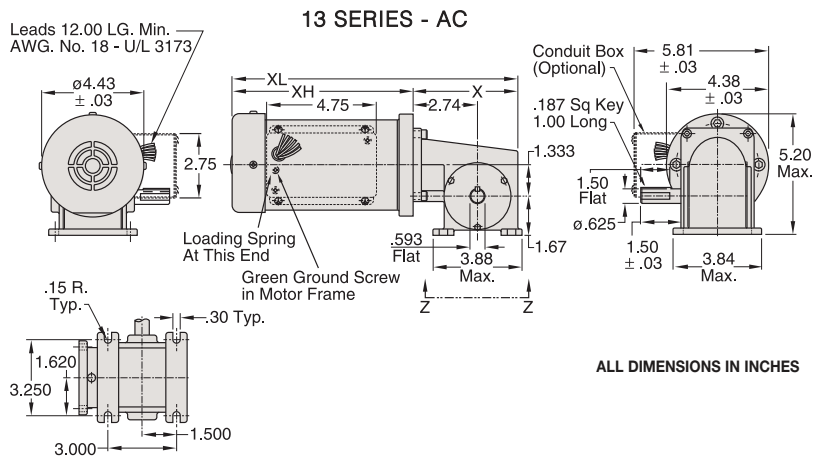
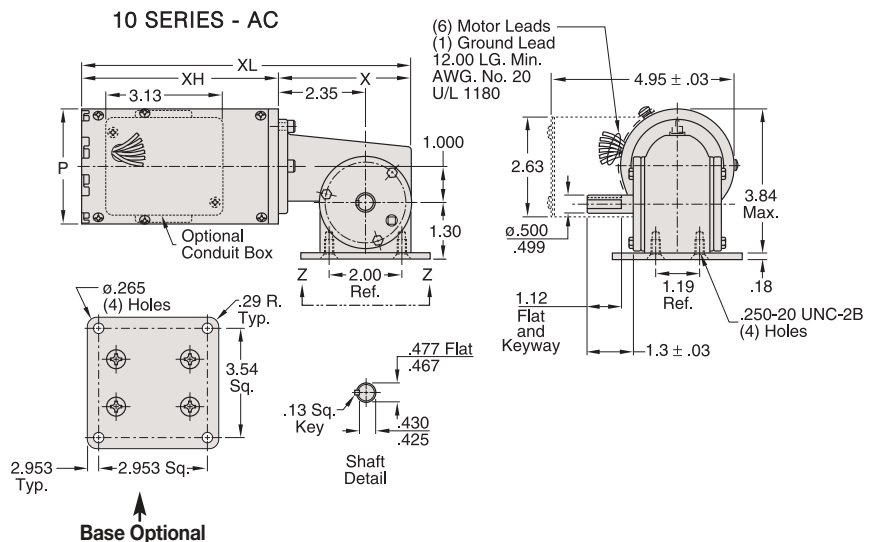

ALL DIMENSIONS IN INCHES



SUB-FHP AC GEARMOTORS INVERTER RATED

Design Specifications:

Three phase motors totally enclosed for continuous duty, general purpose applications.



Standard on all these ratings is the exclusive Inverter Rated Insulation System (IRIS). This provides superior protection against voltage spikes induced by variable frequency drives.

Many superior mechanical features for both the motor and gearbox. Double shielded ball bearings in the motor. Needle bearings in the parallel shaft gearboxes and ball bearings in the Right angle (worm) gearboxes. Steel conduit box provided as Standard. Complete gearmotor furnished with high gloss hardened black enamel paint.

Application Notes:

These motors are designed with high temp insulation (Class F) to avoid over heating when operated with a PWM inverter down to a 10:1 speed range from the printed gearmotor output RPM.

Refer to pages 104 to 106 detailing non-horizontal mounting.

The torque values listed are the recommended full load torque values for reasonable gear life.

Overhung load capacities shown are at the center of the output shaft. See page 107 for optional "L" bracket kits for PZ and PE350 units. Please contact LEESON for output speeds not listed.

P240 SERIES – AC

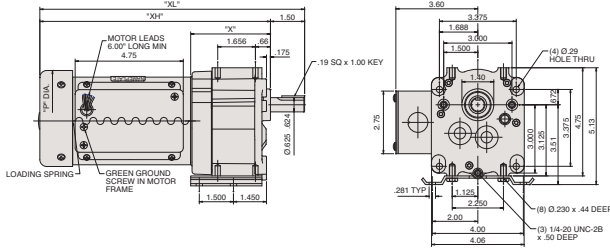

P240 SERIES AC GEARMOTORS THREE PHASE • 230V • TEFC

Output RPM	F.L. Torque (Lb.in.)	Input HP	Catalog Number	Gearmotor Type & Frame	Ratio to 1	F.L. Amps 230V AC	Overhung Load (Lb.)	DIMENSIONS			
								P	X	XL	XH
16	391	1/6	M1145122	P243-38	103	0.72	399	4.43	3.50	11.63	10.13
30	295	1/6	M1145123	P243-38	58	0.72	330	4.43	3.50	11.63	10.13
60	157	1/6	M1145124	P242-38	29	0.72	268	4.43	3.50	11.63	10.13
90	103	1/6	M1145125	P242-38	19	0.72	330	4.43	3.50	11.63	10.13
156	60	1/6	M1145126	P242-38	10.6	0.72	330	4.43	3.50	11.63	10.13

PE350 THREE PHASE

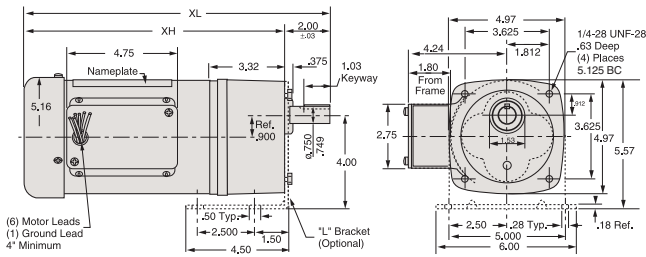

PE350 SERIES AC GEARMOTORS THREE PHASE • 230/460V • TEFC

Output RPM	F.L. Torque (Lb.in.)	Input HP	Catalog Number	Gearmotor Type & Frame	Ratio to 1	F.L. Amps 230V AC	Overhung Load (Lb.)	DIMENSIONS			
								P	X	XL	XH
9	341	1/6	096065	PE353-42	180	1.0	491	5.16	3.32	12.57	10.57
29	300	1/4	096066	PE353-42	58	1.2	327	5.16	3.32	13.07	11.07
58	244	1/4	096067	PE353-42	30	1.2	300	5.16	3.32	13.07	11.07
85	165	1/4	096068	PE352-42	20	1.2	300	5.16	3.32	13.07	11.07
173	92	1/4	096069	PE352-42	10	1.2	300	5.16	3.32	13.07	11.07
345	50	1/4	096070	PE352-42	5	1.2	300	5.16	3.32	13.07	11.07

13 SERIES – AC

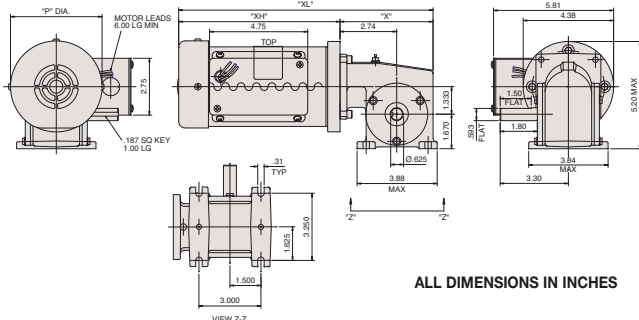

RIGHT ANGLE SERIES AC GEARMOTORS THREE PHASE • 230V • TEFC

Output RPM	F.L. Torque (Lb.in.)	Input HP	Catalog Number	Gearmotor Type & Frame	Ratio to 1	F.L. Amps 230V AC	Overhung Load (Lb.)	DIMENSIONS			
								P	X	XL	XH
29	238	3/8	M1145127	13F60-38	60	1.3	235	4.43	4.50	12.31	7.81
43	228	3/8	M1145128	13F40-38	40	1.3	235	4.43	4.50	12.31	7.81
86	138	3/8	M1145129	13F20-38	20	1.3	235	4.43	4.50	12.31	7.81
172	105	3/8	M1145130	13F10-38	10	1.3	235	4.43	4.50	12.31	7.81
345	54	3/8	M1145131	13F05-38	5	1.3	235	4.43	4.50	12.31	7.81

▲ Use "S" discount symbol.