



# STOCK SUB-FHP DC GEARMOTORS

## PARALLEL SHAFT GEARMOTORS



**SCR RATED:**  
10-100 In-Lbs  
Torque

**LOW VOLTAGE:**  
36-100 In-Lbs  
Torque

### Electrical Specifications:

#### SCR Rated Gearmotors

Totally enclosed, permanent magnet DC gearmotors, performance matched for continuous duty service over a 60:1 speed range. All have constant torque throughout the range when powered by a full-wave unfiltered SCR-type adjustable speed control having a typical form factor of 1.3 to 1.4.

#### Low Voltage Gearmotors

Totally enclosed, permanent magnet DC gearmotors, performance matched for continuous duty. Motors are designed for battery power or can be used with a low voltage controller with form factor up to 1.05.

### Mechanical Specifications:

Precision machined in-line steel gears, with a first stage steel helical gear followed by spur-type gears. Lubrication is permanent semi-fluid grease, reducing possibility of leakage. Output shafts have needle bearings for high load capacities. Shafts are hardened steel.

**Conduit box not included with motor.** Optional conduit box and PZ gearmotor mounting bracket shown on page 156.

### Application Notes:

These gearmotors are designed for mounting at any angle, but motor below the reducer should be avoided to prevent leakage of lubricant into the motor should the motor shaft seal fail.

The motor's stall torque could exceed recommended full load torques. If this service is anticipated, a current limiting device should be used. This issue is even more critical for low voltage motors, typically no controller is used since motor connected directly to battery, so some type of current limit or fusing should be considered.

Overhung load capacities shown are at center of output shaft.

Model PZ gearmotors have the same mounting dimensions as Bodine model D and Z, Baldor/Boehm, Bison 100 gearmotors, and a number of Dayton gearmotors.

## BODINE/BISON/DAYTON DIRECT INTERCHANGE

See Cross Reference page 31.



### SUB-FHP GEARMOTOR "L" MOUNTING BRACKET

Optional "L" bracket used to mount parallel shaft type PZ gearmotor. Of steel construction, bracket is painted and includes screws for mounting to the motor, but not the application.

Catalog Number	For Motors	DIMENSIONS (Inches)									
		A	B	C	D <sup>1</sup>	D <sup>2</sup>	D <sup>3</sup>	X	BA	F	E
M1760003*	PZ Gearmotors	3.75	4.50	3.935	3.00	2.25	1.50	2.645	1.50	1.875	3.75

\* Maximum radial load no greater than 50 lbs.

### PZ SERIES DC • SCR RATED PARALLEL SHAFT • TENV • 1.0 SERVICE FACTOR

Output RPM	F.L. Torque (Lb.In.)	Input HP	Catalog Number	Gearmotor Type & Frame	Ratio to 1	Arm. Volts DC	F.L. Amps DC	Over-hung Load (Lb.)	DIMENSIONS			
									P	X	XL	XH
4	40	1/40	M1115002	PZ5-30A	450	90	0.46	155	3.00	3.25	9.28	7.72
4	40	1/40	M1125046	PZ5-30A	450	180	0.19	155	3.00	3.25	9.30	7.74
10	100	1/20	M1115001	PZ4-30E	180	90	0.54	155	3.00	3.25	9.28	7.72
10	100	1/20	M1125047	PZ4-30A	180	180	0.31	155	3.00	3.25	9.30	7.74
20	100	1/20	M1115000	PZ4-30E	90	90	0.54	155	3.00	3.25	9.28	7.72
20	100	1/20	M1125048	PZ4-30A	90	180	0.31	155	3.00	3.25	9.30	7.74
30	100	1/17	M1125002	PZ3-30B	60	90	0.80	155	3.00	2.68	8.74	7.18
30	100	1/17	M1125037	PZ3-30B	60	180	0.36	155	3.00	2.68	8.74	7.18
60	56	1/17	M1125003	PZ3-30B	30	90	0.80	171	3.00	2.68	8.74	7.18
60	56	1/17	M1125036	PZ3-30B	30	180	0.36	171	3.00	2.68	8.74	7.18
100	36	1/17	M1125004	PZ3-30B	18	90	0.80	171	3.00	2.68	8.74	7.18
100	36	1/17	M1125035	PZ3-30B	18	180	0.36	171	3.00	2.68	8.74	7.18
150	24	1/17	M1125005	PZ2-30B	12	90	0.80	180	3.00	2.40	8.46	6.90
150	24	1/17	M1125034	PZ2-30B	12	180	0.36	180	3.00	2.40	8.46	6.90
300	10	1/17	M1125006	PZ2-30B	6	90	0.80	180	3.00	2.40	8.46	6.90
300	10	1/17	M1125033	PZ2-30B	6	180	0.36	180	3.00	2.40	8.46	6.90

▲ Use "S" discount symbol.

### PZ SERIES DC • LOW VOLTAGE (12V) PARALLEL SHAFT • TENV • 1.0 SERVICE FACTOR

Output RPM	F.L. Torque (Lb.In.)	Input HP	Catalog Number	Gearmotor Type & Frame	Ratio to 1	Arm. Volts DC	F.L. Amps DC	Over-hung Load (Lb.)	DIMENSIONS			
									P	X	XL	XH
10	100	1/20	M1125213	PZ4-30	180	12	2.7	155	3.00	3.25	9.28	7.72
30	100	1/17	M1125214	PZ3-30	60	12	5.2	155	3.00	2.68	8.74	7.18
55	56	1/17	M1125215	PZ3-30	30	12	5.6	171	3.00	2.68	8.74	7.18
90	36	1/17	M1125216	PZ3-30	18	12	5.8	171	3.00	2.68	8.74	7.18

### PZ SERIES - DC

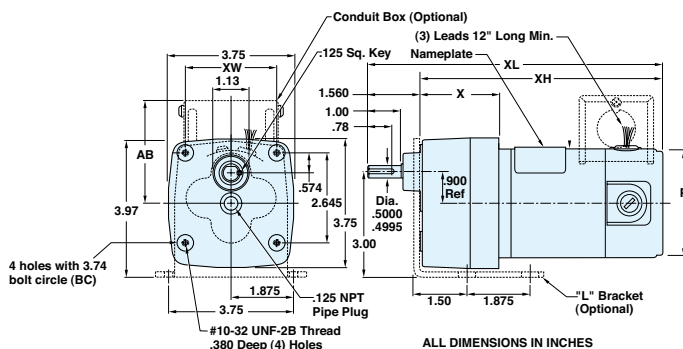

ALL DIMENSIONS IN INCHES

See page 11 for optional conduit box.

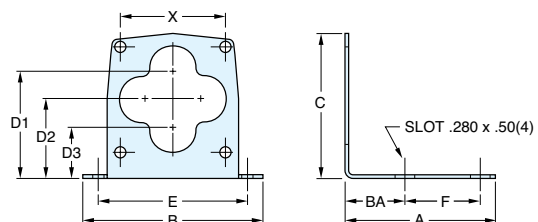

# STOCK SUB-FHP DC GEARMOTORS

## PARALLEL SHAFT GEARMOTORS



**SCR RATED:**  
27-353 In-Lbs  
Torque

**LOW VOLTAGE:**  
113-353 In-Lbs  
Torque

### Electrical Specifications:

#### SCR Rated Gearmotors

Totally enclosed, permanent magnet DC gearmotors, performance matched for continuous duty service over a 60:1 speed range. All have constant torque throughout the range when powered by a full-wave unfiltered SCR-type adjustable speed control having a typical form factor of 1.3 to 1.4.

#### Low Voltage Gearmotors

Totally enclosed, permanent magnet DC gearmotors, performance matched for continuous duty. Motors are designed for battery power or can be used with a low voltage controller with form factor up to 1.05.

### Mechanical Specifications:

Precision machined in-line steel gears, with a first stage steel helical gear followed by spur-type gears. Lubrication is permanent semi-fluid grease, reducing possibility of leakage. Output shafts have needle bearings for high load capacities. Shafts are hardened steel.

**Conduit box *not* included with motor.** Optional conduit box shown on page 156.

### Application Notes:

These gearmotors are designed for mounting at any angle, but shaft up with motor below should be avoided to prevent leakage of lubricant into the motor should the motor's shaft seal fail.

Overhung load capacities shown are at center of output shaft.

The motor's stall torque exceeds recommended full load torques. A current limiting device such as an SCR control should be used to prevent damage.

Model 300 gearmotors have the same mounting dimensions as Bison's 300 and many Dayton gearmotors.

## P300 SERIES DC • SCR RATED

### PARALLEL SHAFT • TENV • 1.0 SERVICE FACTOR

Output RPM	F.L. Torque (Lb.In.)	Input HP	Catalog Number	Gearmotor Type & Frame	Ratio to 1	Arm. Volts DC	F.L. Amps. DC	Overhung Load (Lb.)	DIMENSIONS			
									P	X	XL	XH
5	353	1/20	M1115024	P303-30E	336	90	0.54	565	3.00	3.85	10.07	8.57
9	268	1/20	M1115025	P303-30E	216	90	0.54	474	3.00	3.85	10.07	8.57
18	150	1/20	M1115026	P303-30E	103	90	0.54	385	3.00	3.85	10.07	8.57
24	280	1/8	M1125069	P303-30E	76	90	1.30	353	3.00	3.54	11.54	10.04
31	220	1/8	M1125070	P303-30E	58	90	1.30	327	3.00	3.54	11.54	10.04
31	220	1/8	M1125038	P303-30E	58	180	0.66	327	3.00	3.54	11.54	10.04
34	82	1/20	M1115027	P303-30E	52	90	0.54	318	3.00	3.85	10.07	8.57
51	130	1/8	M1125071	P302-30E	35	90	1.30	277	3.00	3.54	11.54	10.04
51	130	1/8	M1125039	P302-30E	35	180	0.66	277	3.00	3.54	11.54	10.04
51	55	1/20	M1115028	P302-30E	35	90	0.54	281	3.00	3.85	10.07	8.57
61	113	1/8	M1125072	P302-30E	29	90	1.30	267	3.00	3.54	11.54	10.04
60	45	1/20	M1125093	P302-30E	29	180	0.31	267	3.00	3.23	11.54	10.04
94	77	1/8	M1125073	P302-30E	19	90	1.30	236	3.00	3.54	11.54	10.04
94	77	1/8	M1125040	P302-30E	19	180	0.66	236	3.00	3.54	11.54	10.04
109	27	1/20	M1115029	P302-30E	16	90	0.54	224	3.00	3.85	10.07	8.57
106	26	1/20	M1125094	P302-30E	16	180	0.31	222	3.00	3.23	10.07	8.57
167	43	1/8	M1125074	P302-30E	11	90	1.30	197	3.00	3.54	11.54	10.04
170	43	1/8	M1125041	P302-30E	11	180	0.66	196	3.00	3.54	11.54	10.04

## P300 SERIES DC • LOW VOLTAGE (12V)

### PARALLEL SHAFT • TENV • 1.0 SERVICE FACTOR

Output RPM	F.L. Torque (Lb.In.)	Input HP	Catalog Number	Gearmotor Type & Frame	Ratio to 1	Arm. Volts DC	F.L. Amps. DC	Overhung Load (Lb.)	DIMENSIONS			
									P	X	XL	XH
5	353	1/20	M1125217	P303-30	336	12	5.6	565	3.00	3.85	10.07	8.57
31	220	1/8	M1125218	P303-30	58	12	10.6	327	3.00	3.54	11.54	10.04
51	130	1/8	M1125219	P302-30	35	12	10.3	277	3.00	3.23	11.54	10.04
61	113	1/8	M1125220	P302-30	29	12	10.4	267	3.00	3.23	11.54	10.04

### P300 SERIES

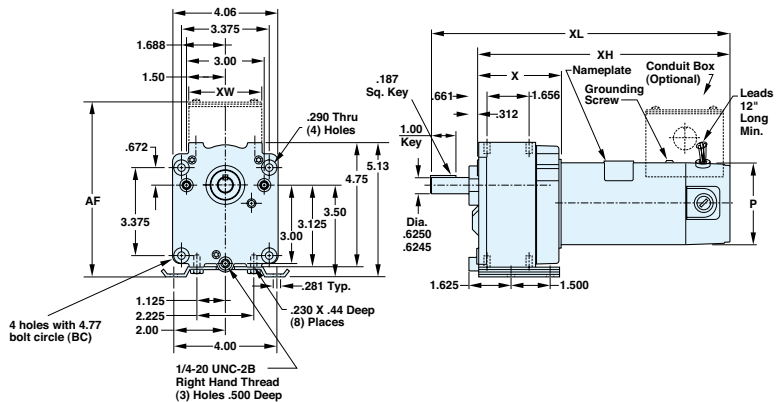

**BISON/DAYTON**  
DIRECT INTERCHANGE

See Cross Reference page 31.

### GEARMOTOR CONDUIT BOX

Optional steel conduit or junction box is available for 24, 30 and 34 frame gearmotors. The box is painted and mounts in holes using screws provided with all stock motors and gearmotors.

Catalog Number	For Motor Frames	DIMENSIONS (Inches)			
		A	B	C	K
M1760000*	24	2.09	2.45	2.23	0.875
M1760021	30/31	3.13	2.63	2.28	0.875
M1760007	34	3.13	2.63	2.28	0.875

M1760000

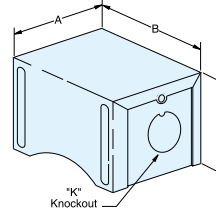

M1760021

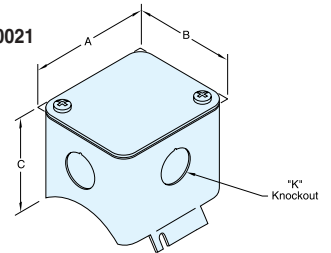

\*For any gearmotor catalog number beginning with M1115XXX, must clarify from gearmotor nameplate which model is listed. For model number beginning with 985XXX, can not use 24 frame conduit box kit. Must use conduit box kit number M1760021. If model number begins with CMXXXXXX, then okay to use 24 frame kit number M176000.



# STOCK SUB-FHP DC GEARMOTORS

## PARALLEL SHAFT GEARMOTORS



**SCR RATED:**  
**25-371 In-Lbs Torque**  
**LOW VOLTAGE:**  
**155-341 In-Lbs Torque**

**Electrical Specifications:**  
**SCR Rated Gearmotors**

Totally enclosed, permanent magnet

DC gearmotors, performance matched for continuous duty service over a 60:1 speed range. All have constant torque throughout the range when powered by a full-wave unfiltered SCR-type adjustable speed control having a typical form factor of 1.3 to 1.4.

### Low Voltage Gearmotors

Totally enclosed, permanent magnet DC gearmotors, performance matched for continuous duty. Motors are designed for battery power or can be used with a low voltage controller with form factor up to 1.05.

### Mechanical Specifications:

Gearbox has rugged aluminum die cast housing, for maximum gear and bearing support. Precision machined gearing, hardened for maximum load capability. All gearing designed and rated to AGMA Class 9 standards and to withstand momentary shock overload of 200%. Oversized output bearings for greater overhung load capacity and longer life. High-carbon alloy output shaft provides maximum strength and rigidity. All needle bearing journals are precision-ground after heat treating, to provide maximum finish and fit. Heavy-duty industrial oil seals help keep lubricant in and dirt out. Gears and bearings are splash lubricated with permanent, heavy-duty gear oil.

**Conduit box not included with motor.** Optional conduit box shown on page 11.

### Application Notes:

These gearmotors are designed for mounting at any angle, but shaft up with motor below should be avoided to prevent leakage of lubricant into the motor should the motor's shaft seal fail.

Overhung load capacities shown are at center of output shaft.

The motor's stall torque exceeds recommended full load torques. A current limiting device such as an SCR control should be used to prevent damage.

Model PE350 gearmotors have the same mounting dimensions as Bodine's "E" box and many Baldor gearmotors.

## PE350 SERIES DC GEARMOTORS PARALLEL SHAFT • TENV • 1.0 S.F. • SCR RATED

Output RPM	F.L. Torque (Lb. In.)	Input HP	Catalog Number	Gearmotor Type & Frame	Ratio to 1	Arm Volts DC	F.L. Amps DC	Overhung Load Lbs.	DIMENSIONS XL Inches	XH Inches
7	330	1/8	M1135106	P353-34	336	90	0.70	565	11.31	9.31
7	330	1/8	M1135139	P353-34	336	180	0.35	565	11.31	9.31
14	341	1/8	M1135107	P353-34	180	90	1.00	465	11.31	9.31
14	341	1/8	M1135140	P353-34	180	180	0.50	465	11.31	9.31
21	371	1/4	M1135117	P353-34	124	90	1.10	413	13.31	11.31
21	371	1/4	M1135141	P353-34	124	180	0.55	413	13.31	11.31
27	305	1/4	M1135115	P353-34	91	90	1.50	374	13.31	11.31
27	305	1/4	M1135142	P353-34	91	180	0.75	374	13.31	11.31
42	280	1/4	M1135108	P353-34	58	90	2.30	327	13.31	11.31
42	280	1/4	M1135143	P353-34	58	180	1.20	327	13.31	11.31
50	250	1/4	M1135109	P353-34	50	90	2.30	315	13.31	11.31
50	250	1/4	M1135144	P353-34	50	180	1.20	315	13.31	11.31
62	220	1/4	M1135110	P353-34	43	90	2.30	303	13.31	11.31
62	220	1/4	M1135145	P353-34	43	180	1.20	303	13.31	11.31
83	155	1/4	M1135114	P352-34	29	90	2.30	267	13.31	11.31
83	155	1/4	M1135146	P352-34	29	180	1.20	267	13.31	11.31
125	100	1/4	M1135111	P352-34	23	90	2.00	256	13.31	11.31
125	100	1/4	M1135147	P352-34	23	180	1.00	256	13.31	11.31
165	70	1/4	M1135112	P352-34	15	90	2.00	232	13.31	11.31
165	70	1/4	M1135148	P352-34	15	180	1.00	232	13.31	11.31
250	45	1/4	M1135116	P352-34	10	90	2.00	201	13.31	11.31
250	45	1/4	M1135149	P352-34	10	180	1.00	201	13.31	11.31
500	25	1/4	M1135113	P352-34	5	90	2.00	194	13.31	11.31
500	25	1/4	M1135150	P352-34	5	180	1.00	194	13.31	11.31

## PE350 SERIES DC • LOW VOLTAGE (12V) PARALLEL SHAFT • TENV • 1.0 SERVICE FACTOR

Output RPM	F.L. Torque (Lb. In.)	Input HP	Catalog Number	Type & Frame	Ratio to 1	Arm Volts DC	F.L. Amps DC	Overhung Load Lbs.	DIMENSIONS XL Inches	XH Inches
14	341	1/8	M1135243	P353-34	180	12	8.7	465	11.05	9.05
42	325	1/4	M1135244	P353-34	58	12	21.0	327	13.31	11.31
62	220	1/4	M1135245	P353-34	43	12	21.0	303	13.31	11.31
83	155	1/4	M1135246	P352-34	29	12	21.0	267	13.31	11.31

**BODINE  
 DIRECT  
 INTERCHANGE**

See Cross Reference page 31.

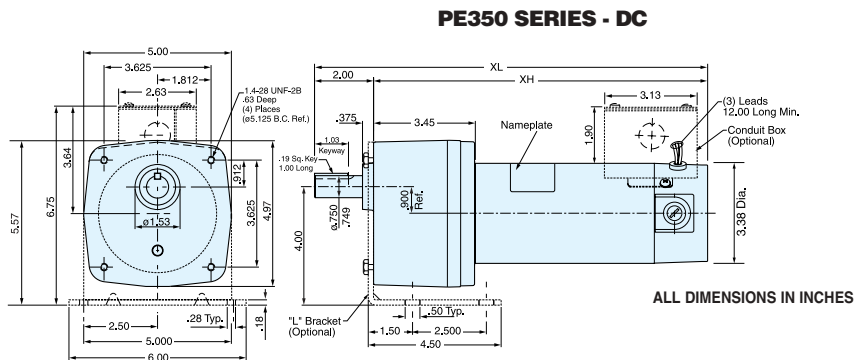

ALL DIMENSIONS IN INCHES

See page 11 for optional conduit box.



### SUB-FHP GEARMOTOR "L" MOUNTING BRACKET

Optional "L" bracket can be used to mount PE350 gearmotors. Of steel construction, bracket is painted and includes screws for mounting to the motor, but not the application.

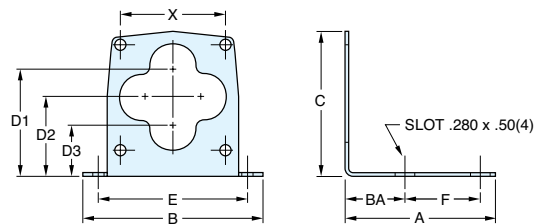

Catalog Number	For Motors	DIMENSIONS (Inches)									
		A	B	C	D <sup>1</sup>	D <sup>2</sup>	D <sup>3</sup>	X	BA	F	E
M1760011*	PE350 Gearmotors	4.50	6.00	5.520	4.00	3.10	2.20	3.625	1.50	2.500	5.00

\* Maximum radial load no greater than 200 lbs.

# STOCK FHP DC GEARMOTORS

## PARALLEL SHAFT GEARMOTORS



**SCR RATED:**  
105-1112 In-Lbs  
Torque

**LOW VOLTAGE:**  
320-1087 In-Lbs  
Torque

### Electrical Specifications:

#### SCR Rated Gearmotors

SCR rated, permanent magnet DC gearmotors. Totally enclosed for continuous duty, general purpose applications. All have constant torque throughout the 60:1 speed range, when powered by a full-wave, unfiltered SCR-type adjustable speed control having a typical form factor of 1.3 to 1.4.

#### Low Voltage Gearmotors

Totally enclosed, permanent magnet DC gearmotors, performance matched for continuous duty. Motors are designed for battery power or can be used with a low voltage controller with form factor up to 1.05.

### Mechanical Specifications:

Gearbox has rugged aluminum die cast housing, for maximum gear and bearing support. Precision machined gearing, hardened for maximum load capability. All gearing designed and rated to AGMA Class 9 standards and to withstand momentary shock overload of 200%. Oversized output bearings for greater overhung load capacity and longer life. High-carbon alloy output shaft provides maximum strength and rigidity. All needle bearing journals are precision-ground after heat treating, to provide maximum finish and fit. Heavy-duty industrial oil seals help keep lubricant in and dirt out. Gears and bearings are splash lubricated with permanent, heavy-duty gear oil. **Conduit box is included as standard.**

### Application Notes:

These gearmotors are designed for mounting at any angle, but shaft-up with motor below gearhead is not recommended. Overhung load capacities shown are at center of output shaft. P1100 DC gearmotors have the same mounting dimensions as Bison 483 gearmotors and many Dayton gearmotors. The motor's stall torque exceeds recommended full load torques. A current limiting device such as an SCR control should be used to prevent damage.

## P1100 SERIES DC GEARMOTORS

### FRACTIONAL HP • PARALLEL SHAFT • TOTALLY ENCLOSED

#### 1.0 SERVICE FACTOR • SCR RATED

Output RPM	F.L. Torque (Lb.In.)	Input HP	Catalog Number	Gearmotor Type & Frame	Ratio to 1	Arm Volts DC	F.L. Amps DC	Overhung Load (Lbs.)	DIMENSIONS XL XH Inches	
8	1087	¼	108700	P1103-48	212	90	2.7	700	14.24	12.74
12	1030	¼	108701	P1103-48	143	90	2.7	700	14.24	12.74
18	750	¼	108702	P1103-48	95	90	2.7	700	14.24	12.74
42	353	¼	108703	P1102-48	42	90	2.7	650	14.24	12.74
60	238	¼	108704	P1102-48	29	90	2.7	625	14.24	12.74
92	160	¼	108705	P1102-48	19	90	2.7	575	14.24	12.74
135	105	¼	108706	P1102-48	13	90	2.7	525	14.24	12.74
18	1112	½	108707**	P1103-48	95	90	5.0	700	16.49	14.99
33	882	½	108708**	P1103-48	53	90	5.0	650	16.49	14.99
42	705	½	108709**	P1102-48	42	90	5.0	650	16.49	14.99
60	476	½	108710**	P1102-48	29	90	5.0	625	16.49	14.99
92	320	½	108711**	P1102-48	19	90	5.0	575	16.49	14.99
135	210	½	108712**	P1102-48	13	90	5.0	525	16.49	14.99

\*\* Totally enclosed fan cooled, others are totally enclosed non-ventilated.

## P1100 SERIES DC • LOW VOLTAGE (12V)

### FRACTIONAL HP • PARALLEL SHAFT • TOTALLY ENCLOSED

#### 1.0 SERVICE FACTOR

Output RPM	F.L. Torque (Lb.In.)	Input HP	Catalog Number	Type & Frame	Ratio to 1	Arm Volts DC	F.L. Amps DC	Overhung Load (Lbs.)	DIMENSIONS XL XH Inches	
8	1087	¼	108729	P1103-48	212	12	21.0	700	13.74	12.24
60	238	¼	108730	P1102-48	29	12	21.0	625	13.74	12.24
42	705	½	108731**	P1102-48	42	12	40.0	650	15.99	14.49
92	320	½	108732**	P1102-48	19	12	40.0	575	15.99	14.49

\*\* TEFC enclosure.

**BISON/DAYTON**  
DIRECT INTERCHANGE

See Cross Reference page 31.

### P1100 SERIES - DC

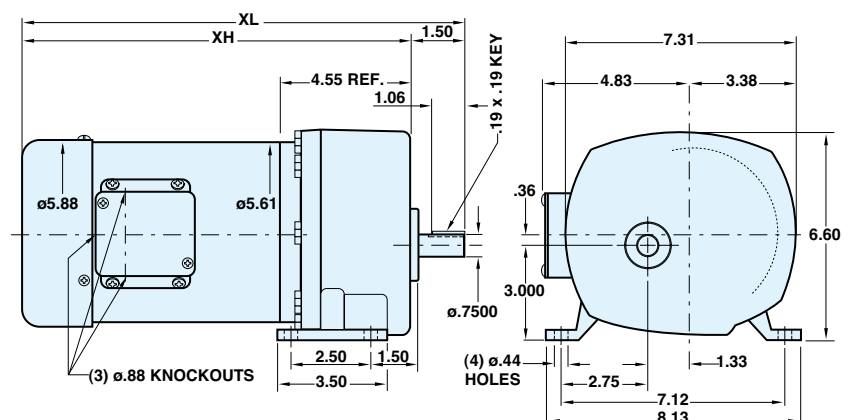

ALL DIMENSIONS IN INCHES



# STOCK SUB-FHP DC GEARMOTORS

## RIGHT-ANGLE SHAFT GEARMOTORS

### RIGHT-ANGLE DC GEARMOTORS TENV • 1.0 SERVICE FACTOR • SCR RATED



**SCR RATED:**  
5-135 In-Lbs  
Torque  
**LOW VOLTAGE:**  
25-135 In-Lbs  
Torque

#### Electrical Specifications:

##### SCR Rated Gearmotors

Totally enclosed right-angle gearmotors, performance matched for continuous service over a 60:1 speed range. All have constant torque throughout the range when powered by a full-wave, unfiltered SCR-type 115 volt input adjustable speed control having a typical form factor of 1.3 to 1.4. Also available as factory options are motors for low voltage input and with double output shafts.

##### Low Voltage Gearmotors

Totally enclosed, permanent magnet DC gearmotors, performance matched for continuous duty. Motors are designed for battery power or can be used with a low voltage controller with form factor up to 1.05.

#### Mechanical Specifications:

This worm-type right-angle gearing features hardened, steel worm with bronze worm wheel for long life and quiet operation. Precision machined aluminum housings are used. Gearbox has all ball bearings. The housing is sealed and lubrication is permanent with an oil bath. The output shaft is field interchangeable from left hand style to right hand style by reassembly.

#### Application Notes:

For optimum seal life, these right-angle gearmotors have a lubrication breather positioned for horizontal mounting. For other mountings, the breather-plug must be reoriented by using a 90°/8" NPT taper pipe elbow (see drawing). Elbow not available from LEESON. Vent plug is available (Part #M1900177.01). However, the motor portion of the gearmotor should never be mounted below the gearhead.

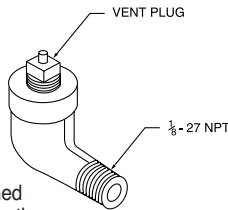

Overhung load capacities shown are at center of output shaft. **Conduit box not supplied with motor.** See page 11 for optional conduit box and optional base kit.

See page 31 for cross reference data between LEESON and other gearmotors.

For additional information on LEESON gearmotors, see Bulletin 1830.

Output RPM	Torque (Lb. In.)	Input HP	Catalog Number	Gearmotor Type & Frame	Ratio to 1	Arm Volts DC	Full Load Amps. DC	Overhung Load (Lbs.)	DIMENSIONS				
									P	PB	X Inches	XL	XH
42	30	1/17	M1115018*	10F60-24	60	90	0.68	185	2.38	3.00	3.60	8.79	5.19
62	35	1/17	M1115019*	10F40-24	40	90	0.68	185	2.38	3.00	3.60	8.79	5.19
125	20	1/17	M1115020*	10F20-24	20	90	0.68	185	2.38	3.00	3.60	8.79	5.19
250	11	1/17	M1115021*	10F10-24	10	90	0.68	185	2.38	3.00	3.60	8.79	5.19
500	6	1/17	M1115022*	10F05-24	5	90	0.68	185	2.38	3.00	3.60	8.79	5.19
42	30	1/12	M1135053	13F60-34	60	180	0.53	235	3.38	4.00	4.50	9.64	5.14
62	35	1/12	M1135054	13F40-34	40	180	0.53	235	3.38	4.00	4.50	9.64	5.14
125	18	1/12	M1135055	13F20-34	20	180	0.53	235	3.38	4.00	4.50	9.64	5.14
250	10	1/12	M1135056	13F10-34	10	180	0.53	235	3.38	4.00	4.50	9.64	5.14
500	5	1/12	M1135057	13F05-34	5	180	0.53	235	3.38	4.00	4.50	9.64	5.14
42	80	1/8	M1135069	13F60-34	60	90	1.40	235	3.38	4.00	4.50	10.64	6.14
62	70	1/8	M1135038	13F40-34	40	90	1.40	235	3.38	4.00	4.50	10.64	6.14
62	70	1/8	M1135058	13F40-34	40	180	0.70	235	3.38	4.00	4.50	10.64	6.14
125	45	1/8	M1135039	13F20-34	20	90	1.40	235	3.38	4.00	4.50	10.64	6.14
125	45	1/8	M1135059	13F20-34	20	180	0.70	235	3.38	4.00	4.50	10.64	6.14
250	25	1/8	M1135040	13F10-34	10	90	1.40	235	3.38	4.00	4.50	10.64	6.14
250	25	1/8	M1135060	13F10-34	10	180	0.70	235	3.38	4.00	4.50	10.64	6.14
500	13	1/8	M1135041	13F05-34	5	90	1.40	235	3.38	4.00	4.50	10.64	6.14
500	13	1/8	M1135061	13F05-34	5	180	0.70	235	3.38	4.00	4.50	10.64	6.14
62	135	1/4	M1135042	13F40-34	40	90	2.30	235	3.38	4.00	4.50	12.64	8.14
62	135	1/4	M1135062	13F40-34	40	180	1.30	235	3.38	4.00	4.50	12.64	8.14
83	125	1/4	M1135043	13F30-34	30	90	2.30	235	3.38	4.00	4.50	12.64	8.14
83	125	1/4	M1135063	13F30-34	30	180	1.30	235	3.38	4.00	4.50	12.64	8.14
125	90	1/4	M1135044	13F20-34	20	90	2.30	235	3.38	4.00	4.50	12.64	8.14
125	90	1/4	M1135064	13F20-34	20	180	1.30	235	3.38	4.00	4.50	12.64	8.14
250	50	1/4	M1135045	13F10-34	10	90	2.30	235	3.38	4.00	4.50	12.64	8.14
250	50	1/4	M1135065	13F10-34	10	180	1.30	235	3.38	4.00	4.50	12.64	8.14
500	30	1/4	M1135046	13F05-34	5	90	2.30	235	3.38	4.00	4.50	12.64	8.14
500	30	1/4	M1135066	13F05-34	5	180	1.30	235	3.38	4.00	4.50	12.64	8.14

\*Mounting base kit available - M1760006

### RIGHT-ANGLE DC • LOW VOLTAGE (12V) TENV • 1.0 SERVICE FACTOR

Output RPM	F.L. Torque (In.-Lbs.)	Input HP	Catalog Number	Gearmotor Type & Frame	Ratio to 1	Arm Volts DC	Full Load Amps. DC	Overhung Load (Lbs.)	DIMENSIONS				
									P	PB	X Inches	XL	XH
42	80	1/8	M1135249	13F60-34	60	12	11.0	235	3.38	4.00	4.50	10.39	5.89
250	25	1/8	M1135250	13F10-34	10	12	11.0	235	3.38	4.00	4.50	10.39	5.89
62	135	1/4	M1135251	13F40-34	40	12	21.0	235	3.38	4.00	4.50	12.64	8.14
125	90	1/4	M1135252	13F20-34	20	12	21.0	235	3.38	4.00	4.50	12.64	8.14

**BODINE/DAYTON  
DIRECT INTERCHANGE**

See Cross Reference page 31.

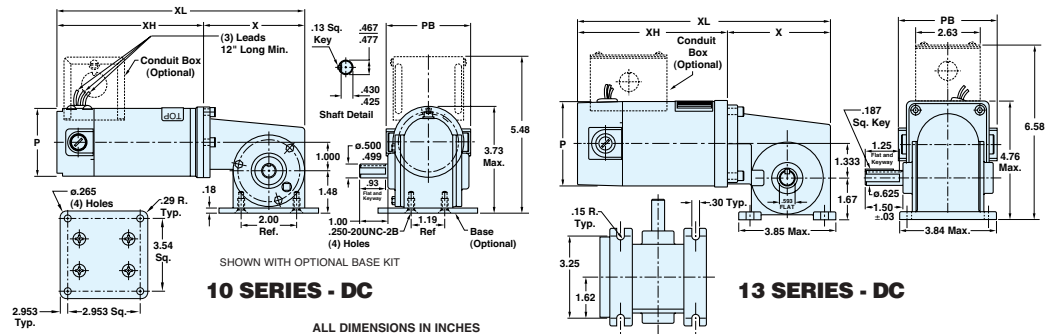

#### 10 SERIES - DC

#### 13 SERIES - DC

ALL DIMENSIONS IN INCHES



#### RIGHT-ANGLE GEARMOTOR BASE KIT

This optional base kit can be used with the 10 series right-angle gearmotors. (Includes screws for mounting to gearbox, but not the application).

Catalog Number
M1760006

See page 11 for optional conduit box.

