



WASHGUARD MOTORS AVAILABLE IN FIVE STYLES



Maximum service in critically clean or corrosive environments

- All exterior components of stainless steel
 - Endshields o-ring sealed to frame
 - IEEE 841 severe-duty features standard
 - Meets demanding pharmaceutical requirements, also excellent for chemical-processing applications
 - Meets IP56 enclosure protection
 - Incorporates all WASHGUARD mechanical and electrical features, plus IRIS™ insulation system
 - IRIS™ insulation system
 - BISSC certified for baking industry
- AC motor catalog listings on page 92
DC motor catalog listings on page 161
IEC Motors now available



Stainless Steel Tough for demanding washdown applications

- All exterior components of 300 series stainless steel, including motor frame, endshield and conduit box castings
 - Moisture resistant sealant between frame and endbells
 - Full-fact nameplate is laser-etched on the motor frame
 - Built to withstand the demanding washdown environments found in the food processing, chemical processing and beverage industries
 - No paint or coatings of any type are used on the exterior of the motor
 - Four locations for T-drains provided on each endshield
 - IRIS™ insulation system
 - Meets IP55 enclosure protection
 - Three phase motors are suitable for use on VFDs
 - 10:1 ratio for constant or variable torque at 1.0 SF
- Catalog listings on page 90



Superior, extended life in severe environments

- Paint-free exterior—stainless frame and conduit box lid, specially processed endshields and conduit box housing
 - Etched stainless steel nameplate
 - Proven WASHGUARD mechanical and electrical features
 - IRIS™ insulation system
 - BISSC certified for baking industry
 - Meets IP55 enclosure protection
 - Three phase motors are suitable for use on VFDs
 - 10:1 ratio for constant or variable torque at 1.0 SF
- Catalog listings on page 88



Enhanced performance in wet, humid areas

- Our original moisture-shedding "duck" motor
 - USDA-approved white epoxy finish
 - Stainless steel shaft, conduit box cover, nameplate, fan guard
 - Special gaskets, slingers and seals
 - Four endshield drains
 - Moisture-resistant interior components
 - IRIS™ insulation system
 - Single-phase, three-phase and DC SCR models
 - Meets IP55 enclosure protection
 - Three phase motors are suitable for use on VFDs
 - 10:1 ratio for constant or variable torque at 1.0 SF
- Catalog listings on pages 85-87



Revolutionary Designed Stainless Steel Motors are built to be the last Stainless Steel Washdown motors you will ever need!

- Meet EPACT for non-exempt when tested without shaft seals
 - Total winding encapsulation using an Epoxy Resin
 - LEESON's exclusive IRIS™ Inverter-Rated Insulation System
 - Motors are UL component recognized
 - CSA Energy Efficiency Verification
 - Construction is CSA Certified for safety
 - All exterior components are 300-Series stainless steel
 - Protech Bearing isolator used for the output shaft seal
 - Double Lip Viton shaft seal used on non-drive output shaft on TEFC motors
 - Minimal exterior fasteners, no through-bolt design and screw on conduit box covers
 - Pre-lubricated double-sealed bearings
 - Rotor/Cartridge, "Q-CAR," for quick access to bearings
 - Rigid Cast Base for rugged applications
 - Full fact nameplate is laser etched
 - BISSC certified for baking industry
- Catalog listings on page 95

Specifications are subject to change without notice



WASHGUARD MOTORS ARE BUILT TO HANDLE HIGH-PRESSURE WASHDOWNS!*

Stainless-steel or white polypropylene fan guard on all WASHGUARD frames.

Composite fan is chemically-inert and static-free. Fan is positively positioned on shaft. On TEFC designs only.

Stainless-steel, "full-fact" nameplate includes information on motor efficiency and connections. Readable even after repeated washdowns.

USDA-approved, white epoxy finish for superior protection and resistance to caustic cleaning solutions.

Encapsulated starting switch (single-phase WASHGUARD motors) uses a patented, field-proven design that is immune to moisture, shock and vibration. No moving parts or exposed contacts to become corroded or inoperable.

Moisture-resistant shaft system includes 303 stainless-steel shaft and lubricated, spring-loaded contact seals in each endshield. Patented V-ring Forshedra seal on shaft end to deflect water (see inset). Double-sealed, oversized bearings lubricated with Exxon POLYREX® EM high temperature, moisture-resistant lubricant. Bearing cavities packed to further retard entrance of moisture.

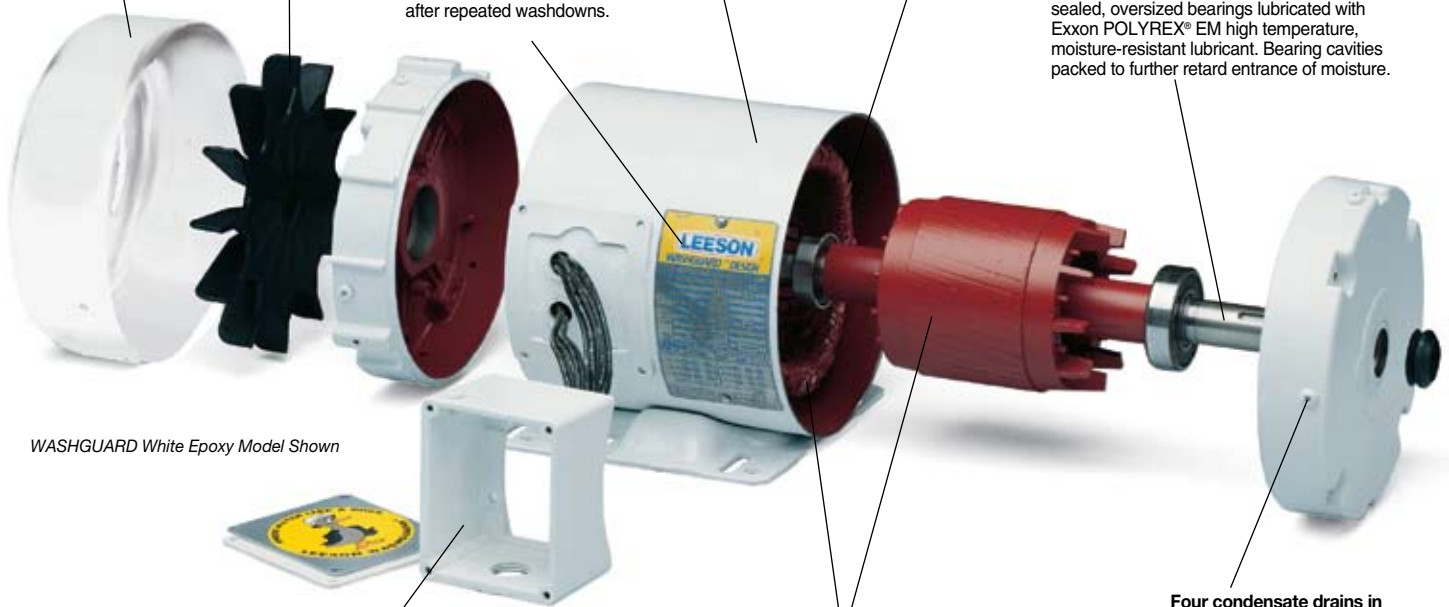

WASHGUARD White Epoxy Model Shown

Cast, oversized conduit box with tough, high-temperature nitrile gaskets and stainless-steel cover and hardware. Oversized design with threaded entrance. All machined fits are sealed and nylon gaskets are used under bolt heads.

Interior coatings protect against moisture and corrosion. Frame, base, endshields, rotor, and interior components are protected by enamel and polyester compounds of outstanding adhesion and resistance to moisture, acids, alkalis, and oils. Efficiencies meet EPACT mandates for covered motors when tested without shaft seals. High temperature, moisture resistant IRIS insulation system assures long life on inverter service. Windings are immersed and cured in polyester insulating compound.



Four condensate drains in each endshield (at three, six, nine, and twelve o'clock) purge condensate and water which may enter the motor.

Meets or exceeds EISA mandates Dec. 2010

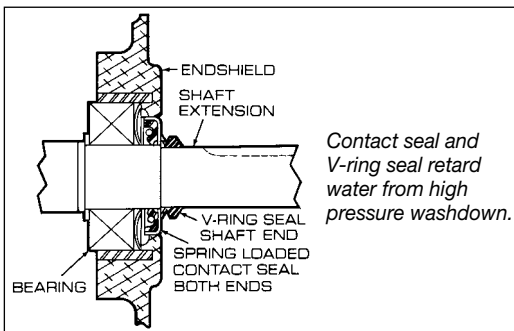

* Also excellent for applications requiring a motor that is "tropicalized"!

QUICK REFERENCE	
WASHGUARD WHITE EPOXY	Page 85
WASHGUARD STAINLESS FRAME	88
WASHGUARD ALL-STAINLESS	90,92,94



White Duck



SINGLE PHASE • TEFC • RIGID BASE

Featuring Electronic Solid State Encapsulated Switch

HP	SYM RPM 60 Hz	NEMA Frame	Catalog Number	App. Wgt. (lbs.)	Voltage	Over-load Prot.	F.L. Amps 230V	"C" Dim. (Inches)
1/2	1800	56	112431.00	24	115/208-230	None	4.4	10.81
3/4	1800	56	112432.00	31	115/208-230	None	5.4	11.31
1	1800	56	112626.00	33	115/208-230	None	6.4	11.81
	1800	143T	120589.00	34	115/208-230	None	6.4	12.25
1 1/2	1800	145T	120590.00	47	115/208-230	None	9.5	13.75
2	1800	182T	131571.00	60	115/208-230	None	12.6	13.46

SINGLE PHASE • TEFC • C FACE LESS BASE

Featuring Electronic Solid State Encapsulated Switch

HP	SYN RPM 60 Hz	NEMA Frame	Catalog Number	App. Wgt. (lbs.)	Voltage	Over-load Prot.	F.L. Amps 230V	"C" Dim. (Inches)
1/3	3600	56C	114310.00	25	115/208-230	None	2.6	10.69
	1800	56C	114311.00	27	115/208-230	None	3.2	10.69
1/2	3600	56C	114312.00	25	115/208-230	None	3.6	10.69
	1800	56C	114313.00	29	115/208-230	None	4.4	11.19
3/4	3600	56C	114314.00	31	115/208-230	None	5.0	11.69
	1800	56C	114315.00	31	115/208-230	None	5.4	11.69
1	3600	56C	114316.00	29	115/208-230	None	6.0	12.19
	1800	56C	114317.00	34	115/208-230	None	6.4	12.19
1 1/2	3600	56C	114318.00	36	115/208-230	None	8.5	12.69
	1800	56C	114319.00	43	115/208-230	None	9.5	13.69

**DC • SCR RATED 90 & 180 VOLTS
TENV • C FACE WITH REMOVABLE BASE**

HP	Full Load RPM	NEMA Frame	Catalog Number	App. Wgt. (lbs.)	Arm. Volts DC	Control Volts AC	F.L. Amps DC	"C" Dim. (Inches)
1/4	1800	S56C	108423.00	23	90	115	2.7	10.69
	1800	S56C	098375.00 A	21	180	230	1.4	10.22
1/3	1800	S56C	108424.00	26	90	115	3.5	11.69
	1800	S56C	098376.00 A	22	180	230	1.7	10.22
1/2	1800	S56C	108226.00	38	90	115	4.9	13.69
	1800	S56C	108227.00	43	180	230	2.4	13.69
3/4	1800	S56C	108228.00	53	90	115	7.0	15.69
	1800	S56C	108229.00	50	180	230	3.5	15.69
1	1800	S56C	108230.00**	45	90	115	10.0	15.81
	1800	S56C	108231.00**	42	180	230	5.0	14.81
1 1/2	1800	S56C	108232.00**	50	180	230	7.6	15.81

** These motors are totally enclosed fan cooled.

A Subject to Availability.

All Washdown Duty motors have Class F Insulation.

SINGLE PHASE • TEFC • C FACE WITH BASE

Featuring Electronic Solid State Encapsulated Switch

HP	SYN RPM 60 Hz	NEMA Frame	Catalog Number	App. Wgt. (lbs.)	Voltage	Over-load Prot.	F.L. Amps 230V	"C" Dim. (Inches)
1/3	3600	56C	113580.00	27	115/208-230	None	2.6	10.69
	1800	56C	112526.00	28	115/208-230	None	3.2	10.69
1/2	3600	56C	113581.00	25	115/208-230	None	3.6	10.69
	1800	56C	112527.00	28	115/208-230	None	4.4	11.19
3/4	3600	56C	113582.00	31	115/208-230	None	5.0	11.69
	1800	56C	112528.00	30	115/208-230	None	5.4	11.69
1	3600	56C	113583.00	31	115/208-230	None	6.0	12.19
	1800	56C	112529.00	33	115/208-230	None	6.4	12.19
1 1/2	3600	56C	113584.00	36	115/208-230	None	8.5	12.69
	1800	56HC	113300.00	45	115/208-230	None	9.5	13.69
2	3600	56HC	114637.00	43	115/208-230	None	10.0	13.69



WASHGUARD MOTORS SHED WATER LIKE A DUCK!



WASHGUARD MOTORS

WHITE EPOXY • THREE PHASE • STANDARD, EPACT & NEMA PREMIUM RATINGS

AC MOTORS



THREE PHASE • TENV and TEFC C FACE LESS BASE

HP	SYN RPM 60 Hz	NEMA Frame	Catalog Number	App. Wgt. (lbs.)	Voltage	F.L. Amps 230V	% F.L. Eff.	"C" Dim. (Inches)
1/4	1800	56C	113649.00●	19	208-230/460	1.1	68.0	9.56
1/3	3600	56C	116640.00●	19	208-230/460	1.1	77.0	10.08
	1800	56C	113954.00●	19	208-230/460	1.3	72.0	9.56
	1800	56C	116642.00	19	208-230/460	1.7	68.0	10.69
1/2	3600	56C	116643.00●	22	208-230/460	1.6	82.5	10.06
	1800	56C	113473.00●	22	208-230/460	1.8	78.5	10.06
	1800	56C	116644.00	22	208-230/460	2.0	74.0	11.19
3/4	3600	56C	113022.00●	23	208-230/460	2.4	84.0	11.06
	1800	56C	113019.00●	28	208-230/460	2.5	80.0	10.56
	1800	56C	116645.00	28	208-230/460	2.8	77.0	11.69
1	3600	56C	113023.00●	35	208-230/460	2.6	85.5	11.56
	1800	56C	113020.00●	32	208-230/460	3.2	80.0	11.56
	1800	56C	116646.00	32	208-230/460	3.8	77.0	11.69
	1800	143TC	120760.00●	35	208-230/460	3.2	80.0	11.75
	1800	143TC	G121652.00	33	208-230/460	3.1	82.5	13.25
1 1/2	3600	56C	113024.00●	42	208-230/460	3.8	84.0	12.56
	1800	56C	113021.00●	44	208-230/460	4.2	84.0	13.06
	1800	56C	116647.00	44	208-230/460	5.0	78.5	12.69
	1800	145TC	120761.00●	47	208-230/460	4.2	84.0	13.25
	1800	145TC	G121655.00	45	208-230/460	4.4	84.0	13.25
2	3600	56C	113593.00●	47	208-230/460	5.0	84.0	13.06
	3600	145TC	121040.00●	45	208-230/460	5.0	84.0	13.12
	1800	56C	114616.00	48	208-230/460	6.2	81.5	12.69
	1800	145TC	G120762.00	47	208-230/460	5.6	84.0	13.75
3	3600	56C	115976.00	39	208-230/460	7.6	84.0	13.19
	3600	145TC	G120987.00	48	208-230/460	7.6	85.5	13.75
	1800	182TC	G131596.00	81	208-230/460	7.6	87.5	14.47
5	3600	184TC	G131595.00	75	208-230/460	12.0	87.5	14.47
	1800	184TC	G131597.00	95	208-230/460	13.0	87.5	14.97
7 1/2	3600	S213TC	G131594.00	102	208-230/460	16.8	88.5	17.47
	1800	213TC	G140467.00	145	208-230/460	20.4	89.5	17.71
10	3600	215TC	G140737.00	170	208-230/460	24.0	89.5	20.57
	1800	215TC	G140465.00	180	208-230/460	26.0	89.5	18.71
15	3600	215TC	G140738.00 A	140	208-230/460	36.0	90.2	20.57

THREE PHASE • TENV and TEFC C FACE WITH BASE

HP	SYN RPM 60 Hz	NEMA Frame	Catalog Number	App. Wgt. (lbs.)	Voltage	F.L. Amps 230V	% F.L. Eff.	"C" Dim. (Inches)
1/4	1800	56C	112523.00	21	208-230/460	1.1	67.0	10.69
1/3	3600	56C	116641.00● A	22	208-230/460	1.1	77.0	10.08
	1800	56C	112547.00	22	208-230/460	1.7	68.0	10.69
1/2	3600	56C	113588.00●	26	208-230/460	1.5	82.5	10.58
	1800	56C	113586.00●	23	208-230/460	1.8	78.5	10.06
	1800	56C	112429.00†	22	208-230/460	2.0	74.0	11.19
	1200	56C	115743.00●	24	208-230/460	2.3	77.0	11.56
3/4	3600	56C	113589.00●	24	208-230/460	2.4	84.0	11.08
	1800	56C	113587.00●	30	208-230/460	2.5	80.0	10.56
	1800	56C	112430.00	26	208-230/460	2.8	77.0	11.19
	1200	56HC	115744.00●□	25	208-230/460	3.0	78.5	13.06
1	3600	56C	113590.00●	34	208-230/460	2.6	85.5	11.58
	1800	56C	112524.00	27	208-230/460	3.8	77.0	11.69
	1800	143TC	121867.00	37	208-230/460	3.2	85.5	13.25
	1200	56HC	115745.00□	35	208-230/460	4.0	77.0	13.08
1 1/2	3600	56C	113591.00●	44	208-230/460	3.8	84.0	12.56
	1800	145TC	121871.00	53	208-230/460	4.8	86.5	13.25
	1800	56C	112643.00	32	208-230/460	5.0	78.5	12.19
	1200	56HC	115746.00□	31	208-230/460	5.7	77.0	14.18
2	3600	56HC	113592.00●♣	48	208-230/460	5.0	84.0	13.06
	3600	145TC	121039.00●	43	208-230/460	4.8	85.5	13.12
	1800	56C	112644.00	36	208-230/460	6.2	81.5	12.69
	1800	145TC	121868.00	49	208-230/460	5.8	86.5	13.75
3	3600	145TC	121870.00	46	208-230/460	7.6	89.5	13.75
	1800	182TC	132198.00	80	208-230/460	7.8	89.5	14.47
5	3600	184TC	132200.00	79	208-230/460	12.0	88.5	14.47
	1800	184TC	132201.00	84	208-230/460	12.8	89.5	14.97
7 1/2	3600	184TC	132199.00	94	208-230/460	17.8	89.5	14.97
	3600	213TC	141120.00	140	208-230/460	17.8	89.5	17.47
	1800	213TC	140822.00	135	208-230/460	21.4	91.7	17.71
10	3600	215TC	140823.00	129	208-230/460	23.6	90.2	20.57
	1800	215TC	140821.00	145	208-230/460	26.6	91.7	18.71

THREE PHASE • TEFC • RIGID BASE

HP	SYN RPM 60 Hz	NEMA Frame	Catalog Number	App. Wgt. (lbs.)	Voltage	F.L. Amps 230V	% F.L. Eff.	"C" Dim. (Inches)
1/2	1800	56	112427.00	24	208-230/460	2.0	74.0	10.81
3/4	1800	56	112428.00	27	208-230/460	2.8	77.0	10.81
1	1800	56	112627.00	26	208-230/460	3.8	77.0	11.31
	1800	143T	121865.00	35	208-230/460	3.1	85.5	12.75
1 1/2	1800	145T	121869.00	51	208-230/460	4.4	86.5	12.75
2	1800	145T	121866.00	46	208-230/460	5.6	86.5	13.75
3	1800	56HZ	115751.00■	45	208-230/460	8.6	82.5	14.25
	1800	182T	132196.00	69	208-230/460	8.2	89.5	13.96
5	3600	184T	132202.00	75	208-230/460	12.0	88.5	14.46
	1800	184T	132197.00	85	208-230/460	13.0	89.5	14.96
7 1/2	3600	184T	132203.00 A	87	208-230/460	16.8	89.5	15.96
	3600	S213T	132204.00 A	87	208-230/460	16.8	89.5	16.59
	1800	213T	140819.00	131	208-230/460	20.4	91.7	17.21
10	1800	215T	140820.00	165	208-230/460	26.0	91.7	18.71

THREE PHASE • 575 VOLTS TEFC • C FACE WITH BASE

HP	SYN RPM 60 Hz	NEMA Frame	Catalog Number	App. Wgt. (lbs.)	Voltage	F.L. Amps 230V	% F.L. Eff.	"C" Dim. (Inches)
1/4	1800	56C	112520.00 A	24	575	0.44	68.0	10.69
1/3	1800	56C	112521.00 A	22	575	0.68	68.0	10.69
1/2	1800	56C	112483.00	28	575	0.8	74.0	10.69
3/4	1800	56C	112484.00	24	575	1.12	77.0	11.19
1	1800	56C	112522.00	30	575	1.5	77.0	11.69

- Combination 56HZ base has mounting holes for NEMA 56 and 143-5T and a standard NEMA 145T frame shaft of 7/8" diameter.
- These motors are totally enclosed, non ventilated—Others are fan cooled.
- ♣ These totally enclosed three phase motors have 1.0 service factors.
- Combination 56H base motors have mounting holes for NEMA 56 and a standard NEMA 56 shaft.
- A Subject to Availability.

All Washdown Duty motors have Class F Insulation.

WATTSAVERe Motors Meet NEMA MG1 part 30 & 31.



THREE PHASE • TEFC • JM PUMP

HP	SYN RPM 60 Hz	NEMA Frame	Catalog Number	App. Wgt. (lbs.)	Voltage	F.L. Amps 230V	% F.L. Eff.	"C" Dim. (Inches)
1	1800	143JM	G121579.00 A	41	208-230/460	3.1	82.5	16.25
1½	3600	143JM	G121580.00 A	33	208-230/460	4.0	82.5	16.25
	1800	145JM	G121581.00 A	47	208-230/460	4.4	84.0	16.25
2	3600	145JM	G121582.00	50	208-230/460	5.2	84.0	16.25
	1800	145JM	G121583.00	49	208-230/460	5.6	84.0	16.75
3	3600	145JM	G121584.00	54	208-230/460	7.6	85.5	16.75
	1800	182JM	G131967.00	79	208-230/460	8.2	87.5	16.75
5	3600	184JM	G131968.00	81	208-230/460	12.0	87.5	16.75
	1800	184JM	G131969.00	95	208-230/460	13.0	87.5	17.63
7½	3600	184JM	G131970.00	110	208-230/460	16.8	88.5	18.25
	1800	213JM	G140733.00	135	208-230/460	20.4	89.5	19.50
10	3600	215JM	G140734.00	142	208-230/460	24.0	89.5	22.20
	1800	215JM	G140735.00 A	150	208-230/460	26.0	89.5	21.70
15	3600	215JM	G140736.00	160	208-230/460	36.0	90.2	22.20

JET PUMP • THREADED SHAFT THREE PHASE • TEFC • C-FACE LESS BASE

HP	SYN RPM 60 Hz	NEMA Frame	Catalog Number	App. Wgt. (lbs.)	Voltage	F.L. Amps 230V	% F.L. Eff.	"C" Dim. (Inches)
¾	3600	56J	116774.00	23	208-230/460	2.4	75.5	10.81
1	3600	56J	116775.00	35	208-230/460	3.2	77.0	10.81
1½	3600	56J	116776.00	42	208-230/460	4.2	81.5	11.81
2	3600	56J	116777.00	47	208-230/460	5.6	82.5	12.31
3	3600	56J	116778.00	49	208-230/460	7.6	84.0	13.25

JET PUMP • THREADED SHAFT THREE PHASE • TEFC • C-FACE WITH BASE

HP	SYN RPM 60 Hz	NEMA Frame	Catalog Number	App. Wgt. (lbs.)	Voltage	F.L. Amps 230V	% F.L. Eff.	"C" Dim. (Inches)
¾	3600	56J	116779.00	24	208-230/460	2.4	75.5	10.81
1	3600	56J	116780.00	36	208-230/460	3.2	77.0	10.81
1½	3600	56J	116781.00	43	208-230/460	4.2	81.5	11.81
2	3600	56J	116782.00	48	208-230/460	5.6	82.5	12.31
3	3600	56J	116783.00	50	208-230/460	7.6	84.0	13.25



WASHGUARD • TENV/TEFC • C FACE WITH BASE

HP	SYN RPM 60 Hz	NEMA Frame	Brake Rating (ft-lbs)	Catalog Number	App. Wgt. (lbs.)	Voltage	F.L. Amps 230V	% F.L. Eff.	"C" Dim. (Inches)
1/3	1800	56C	3	116466.00 ● A	40	208-230/460	1.3	72.0	14.00
1/2	1800	56C	3	116467.00 ●	42	208-230/460	1.8	78.5	14.50
¾	1800	56C	6	116468.00 ● A	44	208-230/460	2.5	80.0	15.00
1	1800	56C	6	116469.00 ●	48	208-230/460	3.2	80.0	15.50
	1800	143TC	6	121616.00 ● A	49	208-230/460	3.2	80.0	16.06
1½	1800	145TC	10	G121617.00	50	208-230/460	4.4	84.0	19.01
2	1800	145TC	10	G121618.00 A	62	208-230/460	5.6	84.0	19.01



WASHGUARD COUPLER BRAKES

Solid die-cast aluminum Stearns NEMA 4X coupler brake converts any TEFC or TENV 56C thru 145TC motor to a fail-safe brakemotor by mounting between the C-face motor and driven equipment. Food safe white epoxy finish. BISSC Certified. Adds 5" to the overall length of 56C thru 145TC WASHGUARD TEFC or TENV motors. Includes all mounting components.

For Both Single and Three Phase Motors

Cat. No. 115/208-230V Single Phase	Cat. No. 208-230/460V Three Phase	Cat. No. 575V Three Phase	Brake Rating (ft-lbs)	Max. HP @ 1725 rpm	Mounts to NEMA Frame	Coupler Brake Output Shaft and Face	App. Wt. (lbs.)
175566.00	175567.00	175568.00	3	1	56C	5/8", 56C	13
175572.00	175573.00	175574.00	6	2	56C/143-5TC	5/8", 56C	14

Larger coupler brakes on page 119.

WASHGUARD BRAKEKITS™

Kit of components including a Stearns NEMA 4X brake to convert 56 thru 145T frame stock TEFC only motors to fail-safe brakemotors. Food safe white epoxy finish. BISSC Certified. Adds 5 1/8" to the overall length of 56 thru 145T WASHGUARD TEFC motors.



WASHGUARD Brakekits™ have the same convenient assembly method as general purpose models.

WASHGUARD • TENV/TEFC • C FACE LESS BASE

HP	SYN RPM 60 Hz	NEMA Frame	Brake Rating (ft-lbs)	Catalog Number	App. Wgt. (lbs.)	Voltage	F.L. Amps 230V	% F.L. Eff.	"C" Dim. (Inches)
1/3	1800	56C	3	116462.00 ● A	39	208-230/460	1.3	72.0	14.00
1/2	1800	56C	3	116463.00 ●	41	208-230/460	1.8	78.5	14.50
¾	1800	56C	6	116464.00 ● A	43	208-230/460	2.5	80.0	15.00
1	1800	56C	6	116465.00 ●	45	208-230/460	3.2	80.0	15.50
	1800	143TC	6	121613.00 ● A	46	208-230/460	3.2	80.0	15.56
1½	1800	145TC	10	121614.00	49	208-230/460	5.0	78.5	18.01
2	1800	145TC	10	121615.00 A	61	208-230/460	6.2	81.5	18.51

A Subject to Availability.

All Washdown Duty motors have Class F Insulation.

WATTSaver Motors Meet NEMA MG1 part 30 & 31.

Catalog Numbers in Green are EPACT Motors.

For 230/460V Three Phase and 230V Single Phase Motors

Brake Rating (ft-lbs)	Mounts to NEMA Frame	Max. HP @ 1725rpm	Cat. No. 208-230/460 V Brake Coil Voltage	App. Wt. (lbs.)
3	56/143-5T	1	175616.00 175771.00②	24
6	56/143-5T	2	175617.00 175772.00②	36
10	56/143-5T	3	175618.00 175773.00②	43

② For 56/145 frame motors having a "B" for the suffix letter for the date code and having a face mount fan guard.

Super Duck



LEESON Severe Duty, stainless frame, WASHGUARD II motors are designed for superior extended service in severe environments. Typical applications include food processing areas requiring frequent sanitation procedures using high pressure cleaning with concentrated caustic solutions, areas of high humidity and in chemical environments.

Mechanical Protection Features

These motors have an *entirely paint free exterior* with 300 series stainless steel motor body, conduit box lid, shaft extension, hardware, fasteners and an etched motor data plate.

To enhance chemical and corrosion resistance, all surfaces of the endbells and conduit box are processed using a U.S. Department of Agriculture approved technique. This proprietary process has been tested and qualified for more than 2,500 hours of salt spray endurance for external surfaces, and 1,000 hours for

internal surfaces. This process has proven successful in food washdown applications and has shown excellent corrosion resistance. Shaft seals, slingers and one-way stainless steel drains retard entrance of contaminants and water into the motor. Multiple, repositional drains provided for all angle mounting, release any water that does enter the motor from hose downs or condensation. Chemically resistant, tough nitrile gaskets and a threaded entrance for power connection also restrict entrance to the motor's interior. Nylon gaskets are used to seal bolt heads.

Bearings used are double sealed and prelubricated with moisture resistant Exxon POLYREX® EM high temperature lubricant.

Electrical Performance and Protection Features

Efficiencies meet EPACT mandates for *covered* motors when tested without shaft seals. High temperature, moisture resistant IRIS insulation system assures long life on inverter service. Windings are immersed and cured in polyester insulating compound. **All Washdown Duty motors have Class F Insulation.**

Standards and Approvals

UL component recognized, file number E57948, guide number PRGY2. Energy efficiency ratings are verified by an independent testing laboratory.

CSA Energy Efficiency Verification Program, report number EEV 78720-1.

Construction is CSA Certified for safety report number LR33543.

WASHGUARD II motors are certified to the Baking Industry Sanitation Standard #29 and listed under BISSC authorization number 769.



STAINLESS FRAME • TENV • C FACE LESS BASE

HP	SYN RPM 60 Hz	NEMA Frame	Catalog Number	App. Wgt. (lbs.)	Voltage	F.L. Amps 230V	% F.L. Eff.	"C" Dim. (Inches)
1/2	1800	56C	114394.00	30	208-230/460	1.6	78.5	11.06
3/4	1800	56C	114395.00	34	208-230/460	2.3	80.0	11.56
1	1800	56C	114437.00	44	208-230/460	3.0	81.5	12.06
	1800	143TC	121109.00	40	208-230/460	3.0	81.5	12.13
1 1/2	1800	56C	114581.00▶	45	208-230/460	4.4	84.0	12.69
	1800	145TC	G121350.00▶	45	208-230/460	4.4	82.5	13.25
2	1800	56C	114582.00▶	51	208-230/460	5.6	84.0	13.69
	1800	145TC	G121351.00▶	52	208-230/460	5.6	84.0	13.75

▶ All ratings TENV except 1/2 & 2 HP, which is TEFC with stainless steel fan cover and chemically inert fan.



STAINLESS FRAME • TENV • C FACE WITH BASE

HP	SYN RPM 60 Hz	NEMA Frame	Catalog Number	App. Wgt. (lbs.)	Voltage	F.L. Amps 230V	% F.L. Eff.	"C" Dim. (Inches)
1/2	1800	56HC	114560.00□	34	208-230/460	1.6	78.5	11.56
3/4	1800	56HC	114561.00□	38	208-230/460	2.3	80.0	12.06
1	1800	56HC	114562.00□	45	208-230/460	2.3	81.5	12.06
	1800	143TC	121165.00	45	208-230/460	2.3	81.5	12.13
1 1/2	1800	145TC	121912.00▶	47	208-230/460	4.4	86.5	13.25
	1800	145TC	121913.00▶	54	208-230/460	5.6	86.5	13.75

▶ All ratings TENV except 1/2 & 2 HP, which is TEFC with stainless steel fan cover and chemically inert fan.
 □ Combination 56H base motors have mounting holes for NEMA 56 and NEMA 143-145T and standard NEMA 56C face and shaft.

CHEMICAL RESISTANCE RATING CHART

CHEMICAL	CONCENTRATION	COMPONENT-RESISTANCE	
		STAINLESS STEEL PARTS	ENDBELLS & CONDUIT BOX
WATER:			
De-Ionized Boiling	100%	Excellent	Excellent
Salt (Immersed)	30%	Excellent	Excellent
Salt (Spray)	5%	Excellent	Excellent
Tap - 250°F/120°C @ 10,000 PSI	100%	Excellent	Excellent
ACIDS:			
Hydrochloric	35%	Poor	Very Good
Sulfuric	25%	Poor	Excellent
Nitric	35%	Excellent	Good
Picric	Saturated Solution	Excellent	Very Good
BASE:			
Caustic	100%	Excellent	Excellent
Caustic	12.5 pH	Excellent	Excellent
Caustic - 125°F/50°C	9.5 pH	Excellent	Excellent
SOLVENTS:			
	--	Excellent	Excellent



WATTSAVERe Motors Meet NEMA MG1 part 30 & 31.

Specifications are subject to change without notice

WASHGUARD SST



This member of LEESON's family of tough ducks is designed for long life in demanding washdown applications. LEESON's FHP WASHGUARD SST All-Stainless motors are Stainless Steel Tough!

Built with all stainless steel external components to prevent corrosion and well sealed against moisture and condensation to protect internal components, the Washguard SST all-stainless motors are able to withstand the severe wash-down environments found in the food processing, chemical processing, and beverage industries.



CHEMICAL RESISTANCE RATING CHART

CHEMICAL	CONCENTRATION	ALL STAINLESS COMPONENTS
WATER:		
De-Ionized Boiling	100%	Excellent
Salt (Immersed)	30%	Excellent
Salt (Spray)	5%	Excellent
Tap - 250°F/120°C @ 10,000 PSI	100%	Excellent
ACIDS:		
Hydrochloric	35%	Poor
Sulfuric	25%	Poor
Nitric	35%	Excellent
Picric	Saturated Solution	Excellent
BASE:		
Caustic	100%	Excellent
Caustic	12.5 pH	Excellent
Caustic - 125°F/50°C	9.5 pH	Excellent
SOLVENTS:		
	-	Excellent

300-Series stainless steel exterior components – frame, base, endshields, shaft extension, fan guard, hardware, conduit box and cover – for maximum corrosion resistance.

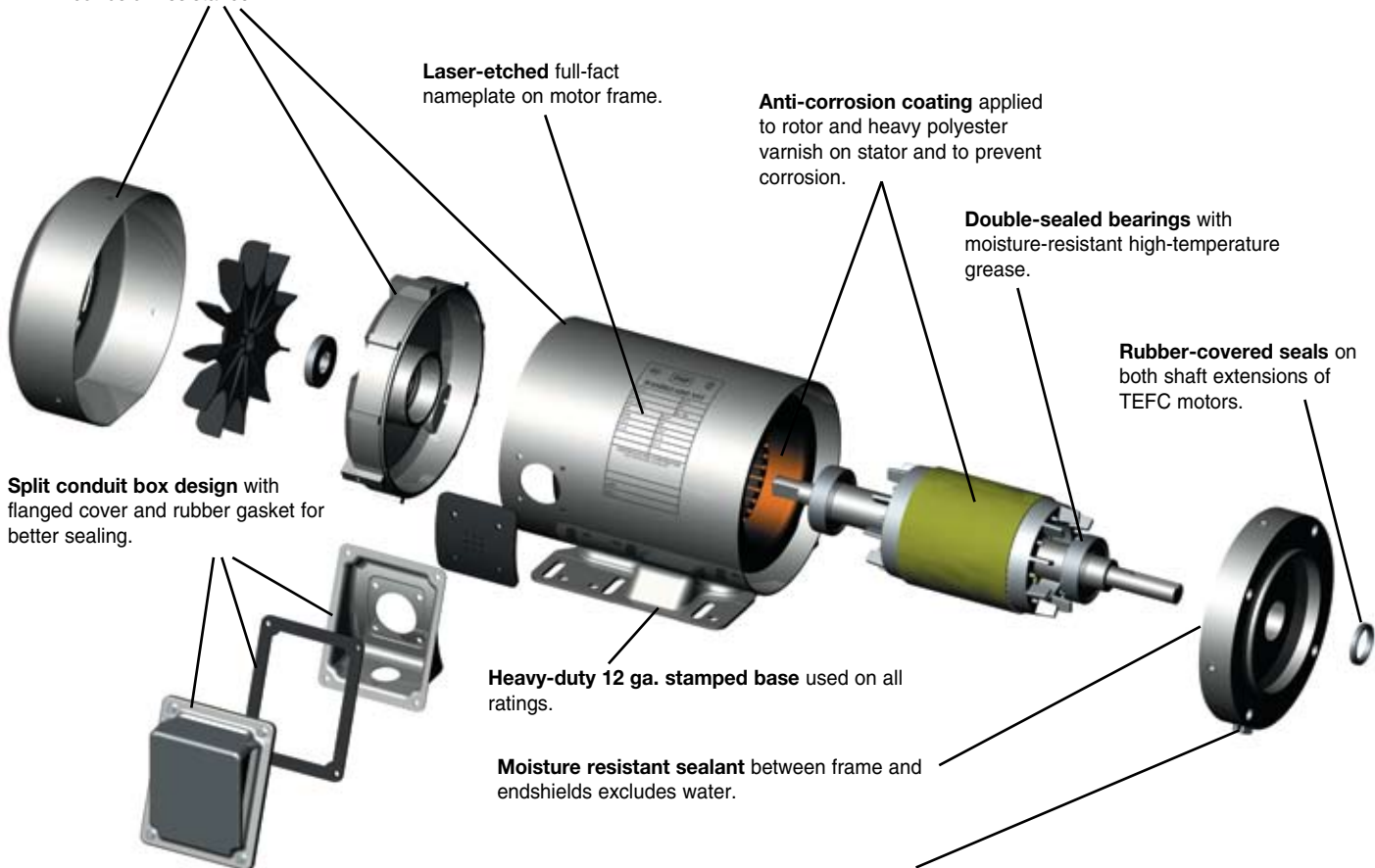

Four condensate drains in each endshield (at three, six, nine and twelve o'clock) provide locations to purge condensate and water, which may enter the motor.

T-drains provided for effective drainage without allowing water to splash inside the motor. T-drain for opposite shaft end is installed at six o'clock position (and can be relocated easily). T-drain for shaft end is shipped loose for customer installation at low point of motor.



CONFORMITE EUROPEENE





WASHGUARD ALL-STAINLESS MOTORS

ALL-STAINLESS • SINGLE-PHASE & THREE-PHASE • STANDARD, EPACT & NEMA PREMIUM RATINGS



WASHGUARD SST

Mechanical Protection Features:

All exterior components – frame, base, endshields, fan guard, shaft, hardware, conduit box and cover – are made from 300 series stainless steel for maximum corrosion resistance. Nameplate data is permanently laser-etched into the motor frame – no Mylar nameplate that can wash off or riveted metal nameplate to trap dirt. No paint or any type of coating is used on the exterior of the motor.

Sealant is applied to endshield and frame fits before assembly to prevent water entry. Shaft seals on both ends of TEFC motors – shaft end only on TENV. Double-sealed bearings have high performance Exxon Polyrex EM grease. Conduit box is fully gasketed half-split design with flanged cover and body gasket with lead separator. Anti-corrosion coating on rotor prevents corrosion. Four quadrant drain locations on each endbell allow drainage of condensation in any mounting position. Stainless steel T-drains are provided to prevent liquids from splashing into the drain locations. Motors are shipped with a T-drain assembled in the six o'clock position on the opposite endshield. Another T-drain is shipped loose in the conduit box for installation at the lowest point of the shaft-end endshield. For a totally sealed motor, a spare pipe plug is included to replace the pre-installed T-drain.

Mechanical performance is further enhanced by over-sized bearings, heavy 12 gauge base, shaft-end bearing is locked internally to limit axial endplay, and specially designed shaft extension resists breakage at bearing journal.

Electrical Performance and Protection Features:

FHP Washguard SST full load efficiencies meet EPACT standards for non-exempt motors when tested without shaft seals. For extra moisture resistance, windings are immersed and cured in polyester insulating varnish. LEESON's exclusive IRIS™ Inverter-Rated Insulation System provides extra protection and long life, especially in inverter driven applications.

10:1 Constant Torque Operation

Standards and Approvals:

UL component recognized, file number E57948, guide number PRGY2. Energy efficiency ratings are verified by an independent testing laboratory.

CSA Energy Efficiency Verification Program, report number EEV 78720-1.

Construction is CSA Certified for safety report number LR33543.

Motor is CE marked for European acceptance.



THREE-PHASE • TENV/TEFC • C FACE WITH BASE

HP	SYN RPM 60 Hz	NEMA Frame	Catalog Number	App. Wgt. (lbs.)	Voltage	F.L. Amps 230V	% F.L. Eff.	"C" Dim. (Inches)
1/3	3600	56C	191200.00●	29	208-230/460	1.0	74.0	9.78
	1800	56C	191201.00●	30	208-230/460	1.3	78.5	9.78
1/2	3600	56C	191203.00●	32	208-230/460	1.5	77.0	9.78
	1800	56C	191204.00●	33	208-230/460	1.6	81.5	9.78
	1200	56C	191414.00●	36	208-230/460	2.0	78.5	9.76
3/4	3600	56C	191206.00●	33	208-230/460	2.0	78.5	9.78
	1800	56C	191207.00●	38	208-230/460	2.3	82.5	9.78
	1200	56C	191415.00●	49	208-230/460	3.0	80.0	11.30
1	3600	56HC	191209.00□	41	208-230/460	2.6	80.0	13.77
	3600	143TC	191486.00	42	208-230/460	2.6	80.0	13.62
	1800	56C	191291.00●①	46	208-230/460	3.0	81.5	11.00
	1800	56HC	191211.00□	47	208-230/460	3.0	82.5	13.77
	1800	143TC	191487.00	48	208-230/460	3.0	85.5	13.62
	1200	56HC	191417.00	49	208-230/460	3.8	82.5	13.10
1 1/2	3600	145TC	191493.00	49	208-230/460	3.8	82.5	13.20
	3600	56HC	191215.00□	48	208-230/460	3.8	82.5	13.77
	3600	143TC	191488.00	49	208-230/460	3.8	84.0	13.62
	1800	56HC	191217.00□	48	208-230/460	4.8	84.0	13.77
	1800	145TC	191489.00	49	208-230/460	4.8	86.5	13.62
	1800	56HC	191221.00□	49	208-230/460	5.0	84.0	13.77
2	3600	145TC	191490.00	50	208-230/460	5.0	85.5	13.62
	1800	56HC	191223.00□	52	208-230/460	5.8	84.0	13.77
	1800	145TC	191491.00	53	208-230/460	5.8	86.5	13.62
3	3600	145TC	191492.00	62	208-230/460	7.4	86.5	14.12

● These motors are totally enclosed, non-ventilated—Others are fan cooled.

□ Combination 56H base motors have mounting holes for NEMA 56 and NEMA 143-5T and a standard NEMA 56 shaft.

① 10:1 Constant Torque Operation



SINGLE-PHASE • TENV/TEFC • C FACE W/BASE

HP	SYN RPM	NEMA Frame	Catalog Number	App. Wgt. (lbs.)	Voltage	F.L. Amps 230V	"C" Dim. (Inches)
1/2	3600	56C	191474.00	29.5	115/208-230	3.1	11.1
	1800	56C	191475.00	31.5	115/208-230	4.1	11.1
3/4	3600	56C	191476.00	31.5	115/208-230	4.5	11.8
	1800	56C	191477.00	39.0	115/208-230	4.9	11.8
1	3600	56C	191478.00	39.0	115/208-230	6.2	12.3
	1800	56C	191479.00	42.5	115/208-230	6.8	12.3
1 1/2	3600	56C	191480.00	42.5	115/208-230	8.8	13.2
	1800	56C	191481.00	52.5	115/208-230	9.5	13.2
2	3600	145TC	191482.00	64.5	115/208-230	10.8	14.2
	1800	145TC	191483.00	64.5	115/208-230	9.0	14.2

THREE-PHASE • TENV/TEFC • C FACE LESS BASE

HP	SYN RPM 60 Hz	NEMA Frame	Catalog Number	App. Wgt. (lbs.)	Voltage	F.L. Amps 230V	% F.L. Eff.	"C" Dim. (Inches)
1/3	1800	56C	191202.00●	30	208-230/460	1.3	78.5	9.78
1/2	1800	56C	191205.00●	33	208-230/460	1.6	81.5	9.78
	1200	56C	191419.00●	35	208-230/460	2.0	78.5	9.76
3/4	1800	56C	191208.00●	38	208-230/460	2.3	82.5	9.78
	1200	56C	191420.00●	47	208-230/460	3.0	80.0	11.30
1	1800	56C	191290.00●	45	208-230/460	3.0	81.5	11.00
	1800	56C	191213.00	47	208-230/460	3.0	82.5	13.77
	1800	143TC	G191214.00	47	208-230/460	3.0	82.5	13.62
1 1/2	1800	56C	191421.00	47	208-230/460	3.8	82.5	13.10
1 1/2	1800	56C	191219.00	48	208-230/460	4.8	84.0	13.77
	1800	145TC	G191220.00	48	208-230/460	4.8	84.0	13.62
2	1800	56C	191225.00	52	208-230/460	5.8	84.0	13.77
	1800	145TC	G191226.00	52	208-230/460	5.8	84.0	13.62

● These motors are totally enclosed, non-ventilated—Others are fan cooled.

WATTSAVERe Motors Meet NEMA MG1 part 30 & 31.

Catalog numbers in Green are EPACT Motors.

Specifications are subject to change without notice

PREMIUM
STAINLESS STEEL DUCK



General Specifications:

Designed specifically to meet the demanding sanitation requirements of the pharmaceutical, food processing and beverage industries. These motors are also ideal in clean room and severe chemical-processing applications involving frequent washdown with nitric acid and caustic lye. In fact, WASHGUARD All-Stainless Motors include IEEE 841 severe-duty features right out of the box! Motors have been tested to and passed the IEC IP-56 test requirements.

Mechanical Protection Features:

- All exterior components are 300-series stainless steel.
- Nothing on the motor's exterior is painted or coated in any way.
- All sealing components are Viton® for superior chemical resistance.
- Full fact nameplate is laser etched on the motor frame – no separately attached nameplate to trap dirt or contaminants.
- Endshields are O-ring sealed to the frame.
- Double lip shaft seals on both ends of TEFC motors (shaft end only on TENV motors).
- Removable hydrophobic breathers in opposite shaft endbell and conduit box equalize pressure without allowing moisture to enter.
- Exterior fastener use minimized reducing the number of entry points for moisture. There are no holes in the frame for attaching a nameplate. Bearing lock screws are located inside the motor and the conduit box mounted screws have been eliminated.
- Double-sealed bearings are pre-lubricated with moisture-resistant high-temperature grease for long life.
- Interior coatings applied to rotor and stator protect against corrosion.
- New conduit box mounting system provides optimum sealing.
- Ease to clean construction is BISSC Certified for bakery applications..

Electrical Performance and Protection Features

- WASHGUARD efficiencies meet EPACT mandates for non-exempt motors when tested without shaft seals.
- Windings are immersed and cured in polyester insulating varnish for extra moisture-resistance.
- LEESON's exclusive IRIS™ Inverter-Rated Insulation System provides extra protection and long life, especially in inverter-driven applications.
- Single-phase motors use Solid State Sinpac® switch – no mechanical switch contacts to corrode and fail.
- All Washdown Duty motors have Class F Insulation.

Standards and Approvals

- Single and three phase motors are UL component recognized – file number E57948, guide number PRGY2.
- CSA Energy Efficiency Verification Program, report number EEV 78720-1.
- Construction is CSA Certified for safety report number LR33543 and listed under BISSC authorization number 769.

300-Series stainless steel exterior components – frame, base, endshields, shaft extension, fan guard, hardware, conduit box and cover – for maximum corrosion resistance.

CHEMICAL RESISTANCE RATING CHART

CHEMICAL	CONCENTRATION	ALL STAINLESS COMPONENTS
WATER:		
De-Ionized Boiling	100%	Excellent
Salt (Immersed)	30%	Excellent
Salt (Spray)	5%	Excellent
Tap - 250°F/120°C @ 10,000 PSI	100%	Excellent
ACIDS:		
Hydrochloric	35%	Poor
Sulfuric	25%	Poor
Nitric	35%	Excellent
Picric	Saturated Solution	Excellent
BASE:		
Caustic	100%	Excellent
Caustic	12.5 pH	Excellent
Caustic - 125°F/50°C	9.5 pH	Excellent
SOLVENTS:		
	-	Excellent

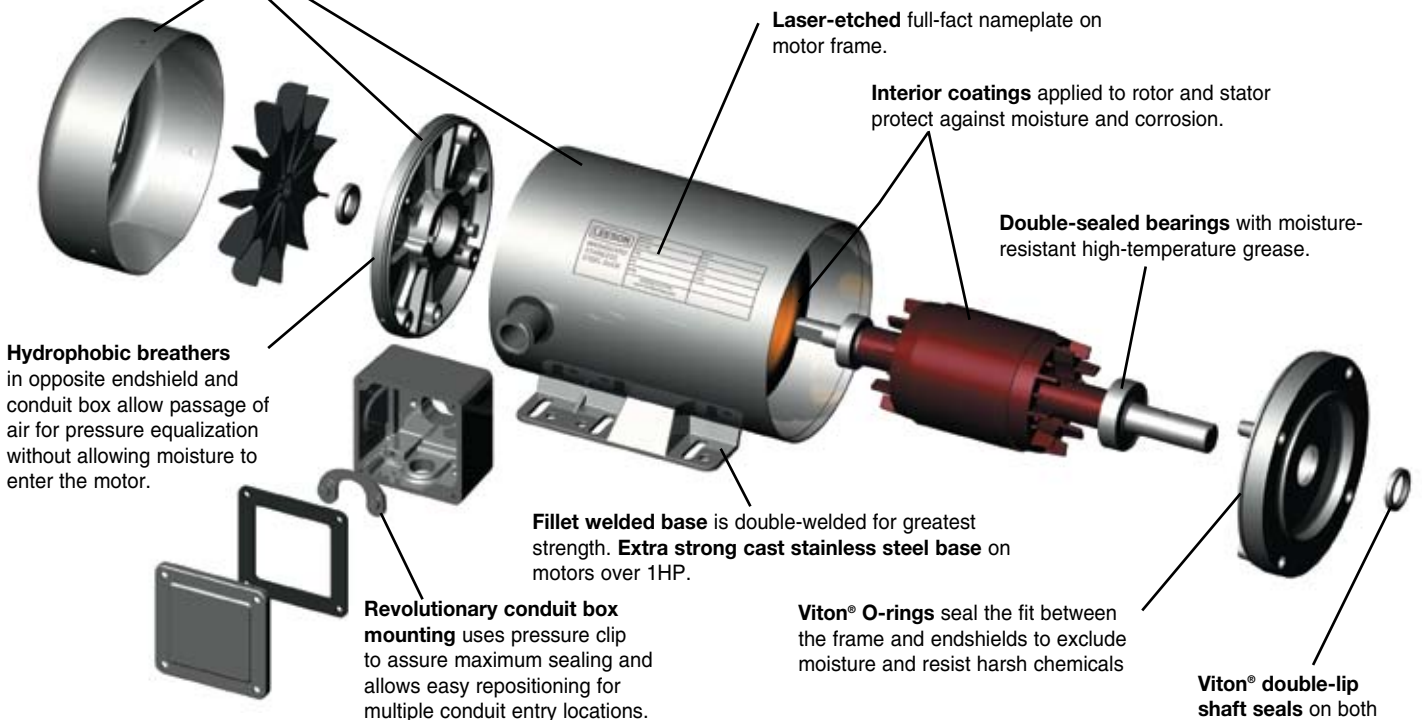

Specifications are subject to change without notice



**PREMIUM
STAINLESS
STEEL DUCK**



THREE PHASE • TENV/TEFC • C FACE WITH BASE

HP	SYN RPM 60 Hz	NEMA Frame	Catalog Number	App. Wgt. (lbs.)	Voltage	F.L. Amps 230V	% F.L. Eff.	"C" Dim. (Inches)
1/2	3600	56HC	117269.00●	35	208-230/460	1.6	82.5	12.04
	1800	S56C	103387.00●	31	208-230/460	1.6	76.0	11.49
	1800	56HC	117266.00●	35	208-230/460	1.6	78.5	12.54
	1200	56HC	117275.00●	35	208-230/460	2.3	77.0	12.54
3/4	3600	56HC	117271.00●	40	208-230/460	2.4	84.0	12.54
	1800	S56C	103388.00	28	208-230/460	2.3	77.0	12.50
	1800	56HC	117267.00●	41	208-230/460	2.3	80.0	13.04
	1200	56HC	117276.00●	46	208-230/460	3.0	78.5	14.04
1	3600	56HC	117273.00●	43	208-230/460	2.6	85.5	13.04
	1800	56HC	115635.00●□	44	208-230/460	3.0	81.5	13.54
	1800	56HC	117286.00	39	208-230/460	3.1	82.5	13.13
	1800	143TC	121795.00●	44	208-230/460	3.0	81.5	13.61
	1800	143TC	121873.00	50	208-230/460	3.1	85.5	13.19
	1200	56HC	117277.00	48	208-230/460	4.0	77.0	13.13
1 1/2	3600	143TC	121874.00	45	208-230/460	4.0	84.0	13.69
	1800	56HC	117284.00	49	208-230/460	4.4	84.0	13.63
	1800	145TC	121875.00	49	208-230/460	4.4	86.5	13.69
	1200	56HC	117278.00	51	208-230/460	5.4	80.0	14.13
2	3600	145TC	121876.00	49	208-230/460	5.2	85.5	13.69
	1800	56HC	117285.00	50	208-230/460	5.6	84.0	13.63
	1800	145TC	121877.00	50	208-230/460	5.6	86.5	13.69
3	3600	145TC	121878.00	53	208-230/460	7.6	86.5	13.69
	1800	182TC	132206.00	85	208-230/460	8.2	89.5	14.77
5	3600	184TC	132207.00	90	208-230/460	12.0	88.5	14.77
	1800	184TC	132208.00	96	208-230/460	13.0	89.5	15.27
7 1/2	3600	213TC	140825.00	160	208-230/460	18.4	89.5	18.69
	1800	213TC	140826.00	160	208-230/460	20.4	91.7	18.69
10	3600	215TC	140827.00	165	208-230/460	24.0	90.2	18.69
	1800	215TC	140828.00	173	208-230/460	26.0	91.7	18.69

- These motors are totally enclosed, non-ventilated—Others are fan cooled.
- Combination 56H base motors have mounting holes for NEMA 56 and NEMA 143-5T and a standard NEMA 56 shaft.

THREE PHASE • TENV/TEFC • C FACE LESS BASE

HP	SYN RPM 60 Hz	NEMA Frame	Catalog Number	App. Wgt. (lbs.)	Voltage	F.L. Amps 230V	% F.L. Eff.	"C" Dim. (Inches)	
1/3	1800	48C	103393.00●	25	208-230/460	1.3	70.5	9.83	
	1/2	3600	56C	117279.00●	35	208-230/460	1.6	82.5	12.04
		1800	48C	103394.00●	27	208-230/460	1.6	76.0	11.58
		1800	S56C	103389.00●	30	208-230/460	1.6	76.0	11.49
3/4	1800	56C	117270.00●	34	208-230/460	1.6	78.5	12.54	
	3600	56C	117280.00●	40	208-230/460	2.4	84.0	12.54	
	1800	S56C	103390.00	33	208-230/460	2.3	77.0	12.50	
	1800	56C	117272.00●	40	208-230/460	2.3	80.0	13.04	
1	3600	56C	117281.00●	43	208-230/460	2.6	85.5	13.04	
	1800	56C	117274.00●	44	208-230/460	3.0	81.5	13.54	
	1800	56HC	117287.00	45	208-230/460	3.1	82.5	13.13	
	1800	143TC	121796.00●	44	208-230/460	3.0	81.5	13.61	
	1800	143TC	G121659.00	51	208-230/460	3.0	82.5	13.19	
	1 1/2	3600	143TC	G121560.00	52	208-230/460	4.0	82.5	13.69
2	1800	56C	117282.00	49	208-230/460	4.4	84.0	13.63	
	1800	145TC	G121525.00	55	208-230/460	5.2	84.0	13.69	
	3600	145TC	G121561.00	54	208-230/460	5.6	84.0	13.69	
3	1800	56C	117283.00	49	208-230/460	5.6	84.0	13.63	
	1800	145TC	G121527.00	60	208-230/460	5.6	84.0	13.69	
	3600	145TC	G121562.00	55	208-230/460	7.6	85.5	13.69	
5	1800	182TC	G131923.00	88	208-230/460	8.2	87.5	14.77	
	3600	184TC	G131949.00	98	208-230/460	12.0	87.5	14.77	
10	1800	184TC	G131924.00	102	208-230/460	13.0	87.5	15.27	

- These motors are totally enclosed, non-ventilated—Others are fan cooled.

Catalog Numbers in Green are EPACT Motors. Specifications are subject to change without notice

SINGLE PHASE • TENV/TEFC • C FACE WITH BASE

HP	SYN RPM 60 Hz	NEMA Frame	Catalog Number	App. Wgt. (lbs.)	Voltage	Over-load Prot.	F.L. Amps 230V	"C" Dim. (Inches)
1/3	1800	56HC	116343.00●□	35	115/208-230	None	2.7	12.20
	3600	56HC	116344.00●□	38	115/208-230	None	3.8	12.20
1/2	1800	56HC	116345.00●□	38	115/208-230	None	3.3	12.70
	3600	56HC	116346.00●□	42	115/208-230	None	3.8	12.70
1	3600	56HC	116347.00●□	49	115/208-230	None	6.0	13.70
	1800	56HC	116348.00●□	49	115/208-230	None	4.5	13.70
1 1/2	3600	56HC	116482.00□	49	115/208-230	None	6.8	13.81
	1800	145TC	121622.00	53	115/208-230	None	7.4	14.81
2	3600	145TC	121623.00	57	115/208-230	None	8.8	14.81
	1800	145TC	121632.00	57	115/208-230	None	10.0	14.81

- These motors are totally enclosed, non-ventilated—Others are fan cooled.
- Combination 56H base motors have mounting holes for NEMA 56 and NEMA 143-5T and a standard NEMA 56 shaft.

SINGLE PHASE • TENV/TEFC • C FACE LESS BASE

HP	SYN RPM 60 Hz	NEMA Frame	Catalog Number	App. Wgt. (lbs.)	Voltage	Over-load Prot.	F.L. Amps 230V	"C" Dim. (Inches)
1/3	1800	56C	116349.00●	35	115/208-230	None	2.7	11.70
	3600	56C	116350.00●	38	115/208-230	None	3.3	12.70
3/4	1800	56C	116351.00●	42	115/208-230	None	3.8	12.70
1	1800	56C	116352.00●	49	115/208-230	None	4.5	13.70
1 1/2	1800	145TC	121624.00	53	115/208-230	None	7.4	14.87
2	1800	145TC	121633.00	57	115/208-230	None	10.0	14.87

- These motors are totally enclosed, non-ventilated—Others are fan cooled.



**BRAKE MOTOR
THREE PHASE • TENV • C FACE WITH BASE**

HP	SYM RPM 60 Hz	NEMA Frame	Brake Rating (ft-lbs)	Catalog Number	App. Wgt. (lbs.)	Voltage	F.L. Amps 230V	% F.L. Eff.	"C" Dim. (Inches)
1/2	1805	56C	3	116483.00●	59	208-230/460	1.6	78.5	15.85
	1	1805	56C	6	116484.00●	69	208-230/460	3.0	81.5

- These motors are totally enclosed, non-ventilated.

THREE PHASE • TEFC • JM PUMP

HP	SYN RPM 60 Hz	NEMA Frame	Catalog Number	App. Wgt. (lbs.)	Voltage	F.L. Amps 230V	% F.L. Eff.	"C" Dim. (Inches)
1	1800	143JM	G121626.00	55	208-230/460	3.0	82.5	16.00
1 1/2	3600	143JM	G121627.00	55	208-230/460	4.0	82.4	16.00
	1800	145JM	G121628.00	56	208-230/460	4.4	84.0	16.00
2	3600	145JM	G121629.00	56	208-230/460	5.2	84.0	16.00
	1800	145JM	G121630.00	57	208-230/460	5.6	84.0	16.50
3	3600	145JM	G121631.00	57	208-230/460	7.6	85.5	16.50
	1800	182JM	G131996.00	85	208-230/460	8.2	87.5	16.20
5	3600	184JM	G131997.00	90	208-230/460	12.0	87.5	16.20
	1800	184JM	G131998.00	96	208-230/460	13.0	87.5	16.77
7 1/2	3600	213JM	G140740.00	160	208-230/460	18.4	88.5	16.81
	1800	213JM	G140741.00	162	208-230/460	20.4	89.5	19.81
10	3600	215JM	G140742.00	165	208-230/460	24.0	89.5	19.81
	1800	215JM	G140743.00	173	208-230/460	26.0	89.5	19.81

WATTSAVERe Motors Meet NEMA MG1 part 30 & 31.



PREMIUM STAINLESS STEEL DUCK



IEC ALL-STAINLESS PREMIUM MOTORS

IEC B5 FLANGE - ROUND BODY

HP/ KW	SYN RPM	Frame	Catalog Number	App. Wgt. (lbs.)	Volts DC	F.L. Amps DC	% FL Eff.	"C" Dim. (Inches)
1/3-0.25	1800	71	103403.00●	30	208-230/460	1.3	70.5	9.87
	1800	80	103405.00●	30	208-230/460	1.3	70.5	9.87
1/2-0.37	1800	71	103404.00●	32	208-230/460	1.6	76.0	11.62
	1800	80	103406.00●	32	208-230/460	1.6	76.0	11.62
3/4-0.55	1800	80	103407.00	38	208-230/460	2.3	77.0	12.26
1- 0.75	1800	90	117516.00	45	208-230/460	3.1	82.5	13.13
1.5 - 1.1	1800	90	117517.00	49	208-230/460	4.4	84.0	13.63
2 - 1.5	1800	90	117518.00	49	208-230/460	5.6	84.0	13.63

IEC B5 FLANGE - RIGID BASE

HP/ KW	SYN RPM	Frame	Catalog Number	App. Wgt. (lbs.)	Volts DC	F.L. Amps DC	% FL Eff.	"C" Dim. (Inches)
1/3-0.25	1800	80	103408.00●	30	208-230/460	1.3	70.5	9.50
1/2-0.37	1800	80	103409.00●	32	208-230/460	1.6	76	12.75
3/4-0.55	1800	80	103410.00	38	208-230/460	2.3	77	12.26

IEC B14 FLANGE - ROUND BODY

HP/ KW	SYN RPM	Frame	Catalog Number	App. Wgt. (lbs.)	Volts DC	F.L. Amps DC	% FL Eff.	"C" Dim. (Inches)
1/3-0.25	1800	71	103395.00●	30	208-230/460	1.3	70.5	9.83
	1800	80	103397.00●	30	208-230/460	1.3	70.5	9.72
1/2-0.37	1800	71	103396.00●	32	208-230/460	1.6	76	11.58
	1800	80	103398.00●	32	208-230/460	1.6	76	11.582
3/4-0.55	1800	80	103399.00	38	208-230/460	2.3	77	12.48

IEC B14 FLANGE - RIGID BASE

HP/ KW	SYN RPM	Frame	Catalog Number	App. Wgt. (lbs.)	Volts DC	F.L. Amps DC	% FL Eff.	"C" Dim. (Inches)
1/3-0.25	1800	80	103400.00●	31	208-230/460	1.3	70.5	9.72
1/2-0.37	1800	80	103401.00●	33	208-230/460	1.6	76	11.58
3/4-0.55	1800	80	103402.00	39	208-230/460	2.3	77	12.48



EXTREME DUCK



General Specifications:

These Revolutionary Designed Stainless Steel Motors are built using our “Voice of the customer” design criteria to withstand extreme washdown and sanitation requirements of the food processing, pharmaceutical, packaging and beverage industries. Our Innovative Hydro Sealed System “HS™” protects from the “outside-in” by reducing entrance points of contaminants and eliminates the need for drain plugs and breathers. This proven process also minimizes exterior hardware, which may trap application elements. Our unique Rotor/Cartridge Seal System, “Q-CAR™” gives quick access to the interior of the motor should the need arise. 300-Series Stainless Steel used on all exterior surfaces gives ideal protection against severe chemical-processing applications and frequent washdown processes using Salt water, Nitric Acids and Solvents.

Mechanical Protection Features:

- All exterior components are 300-Series stainless steel
- Protech Bearing isolator used for the output shaft seal
- Double Lip Viton shaft seal used on non-drive output shaft on TEFC motors
- Minimal exterior fasteners due to no through-bolt design and screw on conduit box covers reduces surface areas that may trap contaminants
- Double-sealed bearings are pre-lubricated with moisture resistant, high temperature grease for long life
- Rotor/Cartridge, “Q-CAR™,” design for quick access to motor interior (patent pending).
- O-ring sealed openings on conduit box covers and Rotor/Cartridge cover
- Rigid Cast Base for rugged applications
- Conduit box lead hole location rotatable on TEFC designs
- Full fact nameplate is laser etched to the motor frame making frame surface smooth, which eliminates areas that trap contaminants
- Ease of clean construction is BISSC certified for bakery applications and motors meet Pharmaceutical Duty specifications
- IP 56 Enclosure protection

Electrical Performance and Protection Features

- Motors meet EPACT mandates for non-exempt motors when tested without shaft seals
- Total winding encapsulation using an Epoxy Resin.
- LEESON’s exclusive IRIS™ Inverter-Rated Insulation System provides extra protection and long life, especially when used in applications driven by an Inverter.
- 3 year warranty
- 10:1 constant torque operation

Standards and Approvals

- Motors are UL component recognized – file number E57948, guide number PRGY2
- CSA Energy Efficiency Verification Program, report number EEV 78720-1
- Construction is CSA Certified for safety, report number LR33543 and listed under BISSC authorization number 769
- 3 year warranty



CHEMICAL RESISTANCE RATING CHART

CHEMICAL	CONCENTRATION	ALL STAINLESS COMPONENTS
WATER:		
De-Ionized Boiling	100%	Excellent
Salt (Immersed)	30%	Excellent
Salt (Spray)	5%	Excellent
Tap - 250°F/120°C @ 10,000 PSI	100%	Excellent
ACIDS:		
Hydrochloric	35%	Poor
Sulfuric	25%	Poor
Nitric	35%	Excellent
Picric	Saturated Solution	Excellent
BASE:		
Caustic	100%	Excellent
Caustic	12.5 pH	Excellent
Caustic - 125°F/50°C	9.5 pH	Excellent
SOLVENTS:		
	-	Excellent

WASHGUARD ALL-STAINLESS MOTORS



ALL-STAINLESS • THREE PHASE • STANDARD & NEMA PREMIUM RATINGS



EXTREME DUCK



AC MOTORS

THREE PHASE • TENV/TEFC • C FACE WITH BASE

HP	SYN RPM 60 Hz	NEMA Frame	Catalog Number	App. Wgt. (lbs.)	Voltage	F.L. Amps 230V	"C" Dim. (Inches)
1/3
1/2	3600	56C	117118.00●	39	208-230/460	1.6	10.47

	1800	S56C	103411.00●	33	208-230/460	1.6	11.49
	1800	56C	117119.00●	40	208-230/460	1.6	10.72
3/4	3600	56C	117120.00●	46	208-230/460	2.4	10.47
	1800	S56C	103412.00	39	208-230/460	2.3	12.50
	1800	56C	117121.00●	47	208-230/460	2.3	11.22
1	3600	56C	117122.00●	48	208-230/460	2.6	10.97
	1800	56C	117123.00●	50	208-230/460	3.0	11.97
1½	3600	143TC	121879.00[w]	54	208-230/460	4.0	11.75
	3600	143TC	G121748.00	54	208-230/460	4.0	11.00
	1800	56C	117296.00	56	208-230/460	4.4	11.69
	1800	145TC	121880.00[w]	56	208-230/460	4.4	12.75
	1800	145TC	G121749.00	56	208-230/460	4.4	11.25
2	3600	145TC	121881.00[w]	56	208-230/460	5.2	12.75
	3600	145TC	G121739.00	56	208-230/460	5.2	12.50
	1800	56C	117299.00[w]	57	208-230/460	5.6	12.69
	1800	145TC	121882.00	57	208-230/460	5.6	13.25
	1800	145TC	G121740.00	57	208-230/460	5.6	12.50

THREE PHASE • TENV/TEFC • C FACE LESS BASE

HP	SYN RPM 60 Hz	NEMA Frame	Catalog Number	App. Wgt. (lbs.)	Voltage	F.L. Amps 230V	"C" Dim. (Inches)
1/3	1800	48C	103417.00●	30	208-230/460	1.3	9.58
1/2	3600	56C	117126.00●	38	208-230/460	1.6	10.47
	1800	48C	103418.00●	32	208-230/460	1.6	11.33
	1800	S56C	103413.00●	32	208-230/460	1.6	11.49
	1800	56C	117127.00●	39	208-230/460	1.6	10.72
3/4	3600	56C	117128.00●	45	208-230/460	2.4	10.47
	1800	S56C	103414.00	38	208-230/460	2.3	12.50
	1800	56C	117129.00●	46	208-230/460	2.3	11.22
1	3600	56C	117130.00●	47	208-230/460	2.6	10.97
	1800	56C	117131.00●	50	208-230/460	3.0	11.69
1½	3600	143TC	121908.00[w]	53	208-230/460	4.0	11.75
	3600	143TC	121750.00	53	208-230/460	4.0	11.00
	1800	56C	117297.00	55	208-230/460	4.4	11.69
	1800	145TC	121909.00[w]	55	208-230/460	4.4	12.75
	1800	145TC	121751.00	55	208-230/460	4.4	11.25
2	3600	145TC	121910.00[w]	55	208-230/460	5.2	12.75
	3600	145TC	121742.00	55	208-230/460	5.2	12.50
	1800	145TC	121743.00	56	208-230/460	5.6	12.50
	1800	145TC	121911.00[w]	56	208-230/460	5.6	13.25
	1800	56C	117298.00	56	208-230/460	5.6	12.69

● These motors are totally enclosed, non-ventilated—Others are fan cooled.
 [w] Premium efficiency WATSAVER[®] Motors. See page 19 for details.

● These motors are totally enclosed, non-ventilated—Others are fan cooled.
 [w] Premium efficiency WATSAVER[®] Motors. See page 19 for details.

Catalog numbers in green are EPACT motors.

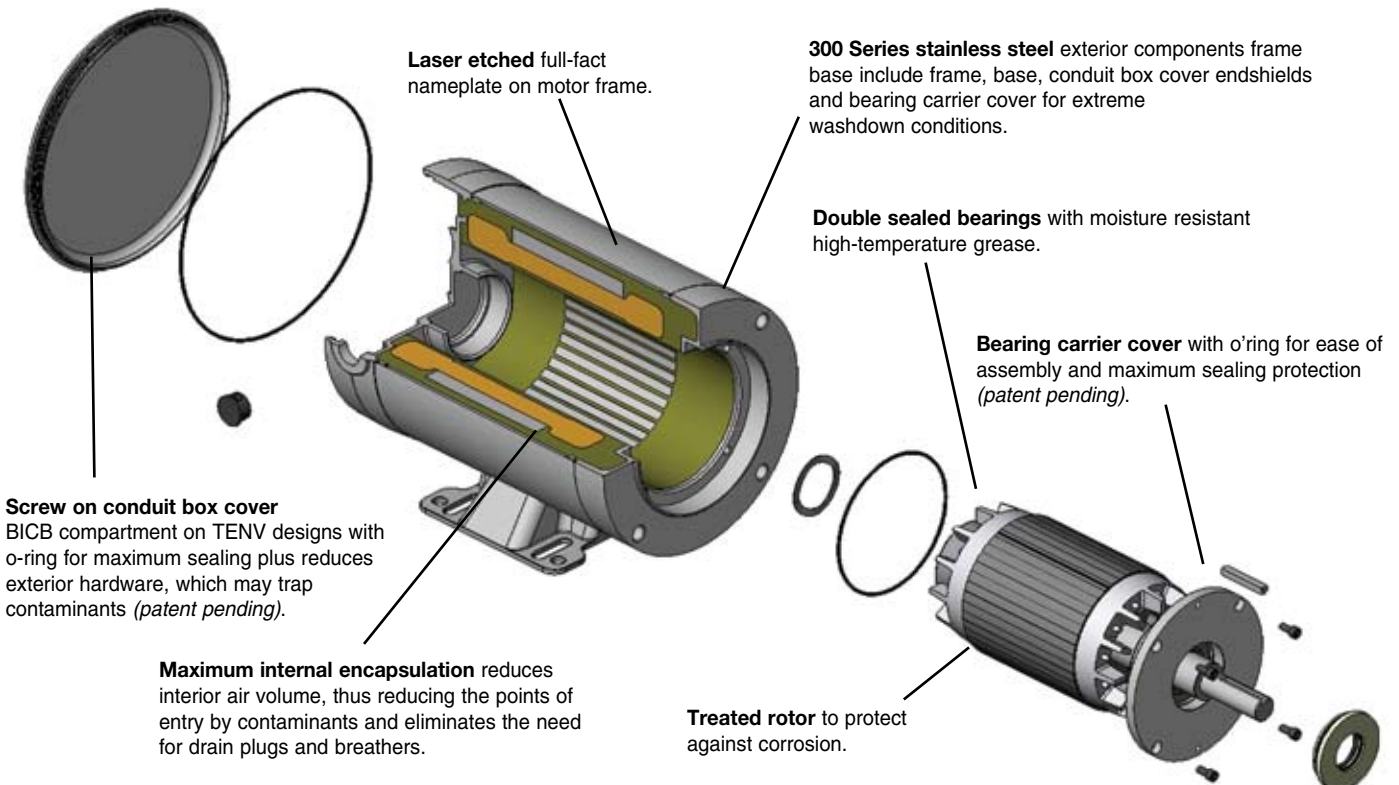



HARSH ENVIRONMENTS WASH-THRU™ MOTORS

230/460 VOLTS • 3-PHASE
FOOT MOUNT & C-FACE

Lincoln's revolutionary Wash-Thru™ design utilizes **Pressure Encapsulation Technology** for unbeatable winding protection and unsurpassed motor life in many harsh environments. Wash-Thru™ motors can provide an improvement in plant efficiency and a reduction in maintenance costs due to an increase in process up-time.

Features:

- Pressure Encapsulation Technology – thermosetting polyester-based resin is forced into and around the motor windings impregnating and encapsulating coil noses and filling stator slots. A silicone-based coating on stator bore surfaces completes the process. The result is unbeatable protection from excessive moisture, chemical action and vibration.
- Full length 303 stainless steel shaft.
- Double-sealed bearings and v-ring shaft slinger.
- Laser etched, stainless steel nameplate for permanent motor identification.
- Premium Class F Insulation system
- FDA approved white finish coat
- Warranty (sine-wave and inverter power) – 18 months from date of manufacture and 12 months from date of installation which ever period expires first.
- Made in U.S.A.

Applications:

Exceptional choice for demanding uses in poultry, seafood, meat and other food processing plants. Other applications include areas where a high degree of dust, moisture, and vibration exist.

Speed ranges (continuous duty) on variable-frequency electronic speed controls (inverters):

Constant Torque: 45 to 60 Hz

Variable Torque: 6 to 60 Hz



Cutaway model shows encapsulated windings.

FOOT MOUNT

HP	SYN RPM	Frame	FL Nom Eff (%)	SF	Volts	Model Number	Product Number	Approx Shpg Wght (lbs)
1/2	3600	56	70.0	1.00	230/460	SREW2S0.5T61	LM21031	30
	1800	56	68.0	1.00	230/460	SREW4S0.5T61	LM20655	26
	1200	56	70.0	1.00	230/460	SREW6S0.5T61	LM25419	28
3/4	3600	56	74.0	1.00	230/460	SREW2S0.75T61	LM21034	30
	1800	56	75.5	1.00	230/460	SREW4S0.75T61	LM20658	24
	1200	56	77.5	1.00	230/460	SREW6S0.75T61	LM22163	33
1	3600	56	78.5	1.00	230/460	SREW2S1T61	LM21037	30
	1800	56	77.0	1.00	230/460	SREW4S1T61	LM21061	30
	1800	143T	77.0	1.00	230/460	SSEW4S1T61	LM20667	35
	1200	56H	72.0	1.00	230/460	SREW6S1T61	LM25420	34
	1200	145T	75.5	1.00	230/460	SSEW6S1T61	LM24280	34
1 1/2	3600	K56	78.5	1.00	230/460	SREW2S1.5T61	LM21040	30
	3600	143T	78.5	1.00	230/460	SSEW2S1.5T61	LM21046	35
	1800	56H	80.0	1.00	230/460	SREW4S1.5T61	LM21062	30
	1800	145T	80.0	1.00	230/460	SSEW4S1.5T61	LM20670	35
	1200	182T	81.5	1.00	230/460	SSEW6S1.5T61	LM25421	35
2	3600	56H	78.5	1.00	230/460	SREW2S2T61	LM21043	34
	3600	145T	82.5	1.00	230/460	SSEW2S2T61	LM21049	35
	1800	56H	81.5	1.00	230/460	SREW4S2T61	LM21063	34
	1800	145T	81.5	1.00	230/460	SSEW4S2T61	LM20673	35
	1200	184T	80.0	1.00	230/460	SSEW6S2T61	LM25422	70

Product numbers in red are STOCK items.

Specifications are subject to change without notice

HARSH ENVIRONMENTS WASH-THRU™ MOTORS

230/460 VOLTS • 3-PHASE
FOOT MOUNT & C-FACE



FOOT MOUNT (cont'd)

HP	SYN RPM	Frame	FL Nom Eff (%)	SF	Volts	Model Number	Product Number	Approx Shpg Wght (lbs)
3	3600	182T	81.5	1.00	230/460	SSEW2S3T61	LM21052	64
	1800	182T	89.5	1.00	230/460	SSEW4S3T61	LM20676	64
	1200	213T	78.5	1.00	230/460	SSEW6S3T61	LM25423	109
5	3600	184T	81.5	1.00	230/460	SSEW2S5T61	LM21055	70
	1800	184T	87.5	1.00	230/460	SSEW4S5T61	LM20679	70
	1200	215T	82.5	1.00	230/460	SSEW6S5T61	LM25424	125
7 1/2	3600	213T	81.5	1.00	230/460	SSEW2S7.5T61	LM22423	109
	1800	213T	81.5	1.00	230/460	SSEW4S7.5T61	LM22435	109
	1200	254T	86.5	1.00	230/460	SSEW6S7.5T61	LM23931	208
10	3600	215T	84.0	1.00	230/460	SSEW2S10T61	LM22426	125
	1800	215T	84.0	1.00	230/460	SSEW4S10T61	LM22438	125

C-FACE WITH FEET

HP	SYN RPM	Frame	FL Nom Eff (%)	SF	Volts	Model Number	Product Number	Approx Shpg Wght (lbs)
1/2	3600	56C	70.0	1.00	230/460	SREW2S0.5TC61	LM21032	35
	1800	56C	68.0	1.00	230/460	SREW4S0.5TC61	LM20656	35
3/4	3600	56C	74.0	1.00	230/460	SREW2S0.75TC61	LM21035	35
	1800	56C	75.5	1.00	230/460	SREW4S0.75TC61	LM20659	35
1	3600	56C	78.5	1.00	230/460	SREW2S1TC61	LM21038	35
	1800	56C	77.0	1.00	230/460	SREW4S1TC61	LM20661	35
	1800	143TC	77.0	1.00	230/460	SSEW4S1TC61	LM20668	40
1 1/2	3600	56C	81.5	1.00	230/460	SREW2S1.5TC61	LM21041	35
	3600	143TC	78.5	1.00	230/460	SSEW2S1.5TC61	LM21047	40
	1800	56HC	80.0	1.00	230/460	SREW4S1.5TC61	LM20663	35
2	1800	145TC	80.0	1.00	230/460	SSEW4S1.5TC61	LM20671	40
	3600	56HC	82.5	1.00	230/460	SREW2S2TC61	LM21044	40
	3600	145TC	78.5	1.00	230/460	SSEW2S2TC61	LM21050	40
3	1800	56HC	81.5	1.00	230/460	SREW4S2TC61	LM20665	40
	1800	145TC	81.5	1.00	230/460	SSEW4S2TC61	LM20674	40
	3600	182TC	81.5	1.00	230/460	SSEW2S3TC61	LM21053	73
5	1800	182TC	81.5	1.00	230/460	SSEW4S3TC61	LM20677	73
	3600	184TC	81.5	1.00	230/460	SSEW2S5TC61	LM21056	79
7 1/2	1800	184TC	81.5	1.00	230/460	SSEW4S5TC61	LM20680	79
	3600	213TC	81.5	1.00	230/460	SSEW2S7.5TC61	LM22424	121
10	1800	213TC	81.5	1.00	230/460	SSEW4S7.5TC61	LM22436	121
	3600	215TC	84.0	1.00	230/460	SSEW2S10TC61	LM22427	139
	1800	215TC	84.0	1.00	230/460	SSEW4S10TC61	LM22439	139

Product numbers in red are STOCK items.

Specifications are subject to change without notice



HARSH ENVIRONMENTS WASH-THRU™ MOTORS

230/460 VOLTS • 3-PHASE
FOOT MOUNT & C-FACE

C-FACE FOOTLESS

HP	SYN RPM	Frame	FL Nom Eff (%)	SF	Volts	Model Number	Product Number	Approx Shpg Wght (lbs)
1/2	3600	56C	70.0	1.00	230/460	SREW2S0.5TCN61	LM21033	35
	1800	56C	74.0	1.00	230/460	SREW4S0.5TCN61	LM20657	35
3/4	3600	56C	74.0	1.00	230/460	SREW2S0.75TCN61	LM21036	35
	1800	56C	77.0	1.00	230/460	SREW4S0.75TCN61	LM20660	35
1	3600	56C	75.5	1.00	230/460	SREW2S1TCN61	LM21039	35
	1800	56C	78.5	1.00	230/460	SREW4S1TCN61	LM20662	35
	1800	143TC	78.5	1.00	230/460	SSEW4S1TCN61	LM20669	40
1 1/2	3600	56C	78.5	1.00	230/460	SREW2S1.5TCN61	LM21042	35
	3600	143TC	78.5	1.00	230/460	SSEW2S1.5TCN61	LM21048	40
	1800	56HC	80.0	1.00	230/460	SREW4S1.5TCN61	LM20664	35
	1800	145TC	80.0	1.00	230/460	SSSEW4S1.5TCN61	LM20672	40
2	3600	56HC	78.5	1.00	230/460	SREW2S2TCN61	LM21045	40
	3600	145TC	78.5	1.00	230/460	SSEW2S2TCN61	LM21051	40
	1800	56HC	81.5	1.00	230/460	SREW4S2TCN61	LM20666	40
1800	145TC	81.5	1.00	230/460	SSEW4S2TCN61	LM20675	40	
3	3600	182TC	81.5	1.00	230/460	SSEW2S3TCN61	LM21054	73
	1800	182TC	81.5	1.00	230/460	SSEW4S3TCN61	LM20678	73
5	3600	184TC	81.5	1.00	230/460	SSEW2S5TCN61	LM21057	79
	1800	184TC	81.5	1.00	230/460	SSEW4S5TCN61	LM20681	79
7 1/2	3600	213TC	81.5	1.00	230/460	SSEW2S7.5TCN61	LM22425	121
	1800	213TC	81.5	1.00	230/460	SSEW4S7.5TCN61	LM22437	121
10	3600	215TC	84.0	1.00	230/460	SSEW2S10TCN61	LM22428	139
	1800	215TC	84.0	1.00	230/460	SSEW4S10TCN61	LM22440	139

Product numbers in red are STOCK items.

Specifications are subject to change without notice

ODP – ENCAPSULATED MULTIGUARD®



230/460 & 460 VOLTS • 3-PHASE
FOOT MOUNT, C-FACE & DOUBLE C-FACE/DOUBLE SHAFT
15 TO 250 HP

AC MOTORS

Features:

- Encapsulated Windings
- NEMA Design B performance
- Durable steel frame, cast iron end brackets
- Premium Class F Plus Insulation System
- Continuous Duty, 40°C ambient
- Reduced voltage start capability –
284T-405T: Y-delta start on either voltage
444T-445T: Y-delta start and part-winding start
- Warranty: 42 months from date of manufacture or 36 months from date of installation, whichever period expires first.
- Made in U.S.A.



Stator/frame assembly pictured – end brackets removed to show encapsulation.

Applications:

Multiguard motors utilize an ODP enclosure with a winding protection system unique to the motor industry. The windings are impregnated and encapsulated in a thermosetting, specially formulated polyester based resin using a high pressure injection-molding process. When compared to a standard ODP and in some cases TEFC, it performs better in applications involving moisture, vibration, dust and some chemical action.

FOOT MOUNT

HP	SYN RPM	Frame	FL Nom Eff (%)	SF	Volts	Model Number	Product Number	Approx Shpg Wght (lbs)
15	1200	284T	86.5	1.00	230/460	MD6S15T61	LM03614	280
	1200	284TS	86.5	1.00	230/460	MD6S15TS61	LM10636	280
20	1200	286T	84.0	1.00	230/460	MD6S20T61	LM03631	328
	1200	286TS	84.0	1.00	230/460	MD6S20TS61	LM10637	328
25	1800	284T	87.5	1.00	230/460	MD4S25T61	LM03618	296
	1800	284TS	87.5	1.00	230/460	MD4S25TS61	LM10638	296
	1200	324T	89.5	1.00	230/460	MD6S25T61	LM03665	422
	1200	324TS	89.5	1.00	230/460	MD6S25TS61	LM10639	422
30	3600	284T	82.5	1.00	230/460	MD2S30T61	LM03628	306
	3600	284TS	82.5	1.00	230/460	MD2S30TS61	LM03627	306
	1800	286T	87.5	1.00	230/460	MD4S30T61	LM03636	334
	1800	286TS	87.5	1.00	230/460	MD4S30TS61	LM03637	334
	1200	326T	89.5	1.00	230/460	MD6S30T61	LM03865	482
	1200	326TS	89.5	1.00	230/460	MD6S30TS61	LM10640	482
40	3600	286T	84.0	1.00	230/460	MD2S40T61	LM03651	350
	3600	286TS	84.0	1.00	230/460	MD2S40TS61	LM03650	350
	1800	324T	90.2	1.00	230/460	MD4S40T61	LM03669	420
	1800	324TS	90.2	1.00	230/460	MD4S40TS61	LM03670	420
	1200	364T	91.7	1.00	230/460	MD6S40T61	LM03703	655
	1200	364TS	91.7	1.00	230/460	MD6S40TS61	LM10641	655
50	3600	324T	86.5	1.00	230/460	MD2S50T61	LM03682	425
	3600	324TS	86.5	1.00	230/460	MD2S50TS61	LM03681	425
	1800	326T	91.7	1.00	230/460	MD4S50T61	LM03683	476
	1800	326TS	91.7	1.00	230/460	MD4S50TS61	LM03684	476
	1200	365T	91.7	1.00	230/460	MD6S50T61	LM03720	690
	1200	365TS	91.7	1.00	230/460	MD6S50TS61	LM10642	690
60	3600	326T	87.5	1.00	230/460	MD2S60T61	LM03692	484
	3600	326TS	87.5	1.00	230/460	MD2S60TS61	LM03691	484
	1800	364T	92.4	1.00	230/460	MD4S60T61	LM03709	627
	1800	364TS	92.4	1.00	230/460	MD4S60TS61	LM03708	627
	1200	404T	92.4	1.00	230/460	MD6S60T61	LM03785	855
	1200	404TS	92.4	1.00	230/460	MD6S60TS61	LM10643	855

Product numbers in red are STOCK items.

Specifications are subject to change without notice



ODP - ENCAPSULATED MULTIGUARD®

230/460 & 460 VOLTS • 3-PHASE
FOOT MOUNT, C-FACE & DOUBLE C-FACE/DOUBLE SHAFT
15 TO 250 HP

FOOT MOUNT (cont'd)

HP	SYN RPM	Frame	FL Nom Eff (%)	SF	Volts	Model Number	Product Number	Approx Shpg Wght (lbs)
75	3600	364T	88.5	1.00	230/460	MD2S75T61	LM03719	644
	3600	364TS	88.5	1.00	230/460	MD2S75TS61	LM03718	644
	1800	365T	91.7	1.00	230/460	MD4S75T61	LM03729	697
	1800	365TS	91.7	1.00	230/460	MD4S75TS61	LM03728	697
	1200	405T	92.4	1.00	230/460	MD6S75T61	LM03799	948
	1200	405TS	92.4	1.00	230/460	MD6S75TS61	LM03800	948
100	3600	365T	88.5	1.00	230/460	MD2S100T61	LM03740	712
	3600	365TS	88.5	1.00	230/460	MD2S100TS61	LM03739	712
	1800	404T	93.0	1.00	230/460	MD4S100T61	LM03791	865
	1800	404TS	93.0	1.00	230/460	MD4S100TS61	LM03790	865
	1200	444T	94.1	1.00	460	MD6S100T64PY	LM03752	1,213
	1200	444TS	94.1	1.00	460	MD6S100TS64PY	LM03753	1,213
125	3600	404T	89.5	1.00	230/460	MD2S125T61	LM10644	875
	3600	404TS	89.5	1.00	230/460	MD2S125TS61	LM03797	875
	1800	405T	93.0	1.00	230/460	MD4S125T61	LM03809	972
	1800	405TS	93.0	1.00	230/460	MD4S125TS61	LM03808	972
	1200	445T	94.1	1.00	460	MD6S125T64PY	LM03768	1,377
	1200	445TS	94.1	1.00	460	MD6S125TS64PY	LM10645	1,377
150	3600	405T	89.5	1.00	230/460	MD2S150T61	LM03816	978
	3600	405TS	89.5	1.00	230/460	MD2S150TS61	LM03815	978
	1800	444T	93.6	1.00	460	MD4S150T64PY	LM03761	1,230
	1800	444TS	93.6	1.00	460	MD4S150TS64PY	LM03760	1,230
	200	445T	94.5	1.00	460	MD4S200T64PY	LM03773	1,440
	1800	445TS	94.5	1.00	460	MD4S200TS64PY	LM03772	1,440
250	1800	445T	93.6	1.00	460	MD4S250T64PY	LM03780	1,500
	1800	445TS	93.6	1.00	460	MD4S250TS64PY	LM03779	1,500

C-FACE WITH FEET

HP	SYN RPM	Frame	FL Nom Eff (%)	SF	Volts	Model Number	Product Number	Approx Shpg Wght (lbs)
15	1200	284TC	86.5	1.00	230/460	MD6S15TC61	LM03616	287
	1200	284TSC	86.5	1.00	230/460	MD6S15TSC61	LM03615	287
20	1200	286TC	84.0	1.00	230/460	MD6S20TC61	LM03633	335
	1200	286TSC	84.0	1.00	230/460	MD6S20TSC61	LM03632	335
25	1800	284TC	87.5	1.00	230/460	MD4S25TC61	LM03623	303
	1800	284TSC	87.5	1.00	230/460	MD4S25TSC61	LM03619	303
	1200	324TC	89.5	1.00	230/460	MD6S25TC61	LM03666	432
30	1800	286TC	87.5	1.00	230/460	MD4S30TC61	LM03643	343
	1800	286TSC	87.5	1.00	230/460	MD4S30TSC61	LM03639	343
	1200	326TC	89.5	1.00	230/460	SE6S30TC61	LM20488	482
40	1800	324TC	90.2	1.00	230/460	MD4S40TC61	LM03673	439
	1800	324TSC	90.2	1.00	230/460	MD4S40TSC61	LM03671	439
	1200	364TC	91.7	1.00	230/460	MD6S40TC61	LM03705	667
50	1800	326TC	91.7	1.00	230/460	MD4S50TC61	LM03686	486
	1800	326TSC	91.7	1.00	230/460	MD4S50TSC61	LM03685	486
	1200	365TC	91.7	1.00	230/460	MD6S50TC61	LM03724	702
60	1800	364TC	92.4	1.00	230/460	MD4S60TC61	LM03711	639
	1800	364TSC	92.4	1.00	230/460	MD4S60TSC61	LM03713	639
75	1800	365TC	91.7	1.00	230/460	MD4S75TC61	LM03730	709
	1800	365TSC	91.7	1.00	230/460	MD4S75TSC61	LM03733	709
	1200	405TC	92.4	1.00	230/460	MD6S75TC61	LM03804	964
100	1800	404TC	93.0	1.00	230/460	MD4S100TC61	LM03792	881
	1800	404TSC	93.0	1.00	230/460	MD4S100TSC61	LM03794	881
	1200	444TSC	94.1	1.00	460	MD6S100TSC64PY	LM03755	1234

Product numbers in red are STOCK items.

Specifications are subject to change without notice

ODP - ENCAPSULATED MULTIGUARD®



AC MOTORS

230/460 & 460 VOLTS • 3-PHASE
FOOT MOUNT, C-FACE & DOUBLE C-FACE/DOUBLE SHAFT
15 TO 250 HP

C-FACE WITH FEET (cont'd)

HP	SYN RPM	Frame	FL Nom Eff (%)	SF	Volts	Model Number	Product Number	Approx Shpg Wght (lbs)
125	1800	405TC	93.0	1.00	230/460	MD4S125TC61	LM03810	988
	1800	405TSC	93.0	1.00	230/460	MD4S125TSC61	LM03812	988
	1200	445TSC	94.1	1.00	460	MD6S125TSC64PY	LM03770	1398
150	1800	444TSC	93.6	1.00	460	MD4S150TSC64PY	LM03763	1251
200	1800	445TSC	94.5	1.00	460	MD4S200TSC64PY	LM03776	1435
250	1800	445TSC	93.6	1.00	460	SE4S250TSC64PY	LM16564	1600

DOUBLE C-FACE/DOUBLE SHAFT

HP	SYN RPM	Frame	FL Nom Eff (%)	SF	Volts	Model Number	Product Number	Approx Shpg Wght (lbs)
15	1200	284TC	86.5	1.00	230/460	MD6S15TCTMC61	LM10725	295
	1200	284TSC	86.5	1.00	230/460	MD6S15TSTSC61	LM10726	295
20	1200	286TC	84.0	1.00	230/460	MD6S20TCTMC61	LM10727	342
	1200	286TSC	84.0	1.00	230/460	MD6S20TSTSC61	LM03634	342
25	1800	284TC	87.5	1.00	230/460	MD4S25TCTMC61	LM03624	310
	1800	284TSC	87.5	1.00	230/460	MD4S25TSTSC61	LM03625	310
	1200	324TC	89.5	1.00	230/460	MD6S25TCTMC61	LM03667	442
	1200	324TSC	89.5	1.00	230/460	MD6S25TSTSC61	LM03668	442
30	1800	286TC	87.5	1.00	230/460	MD4S30TCTMC61	LM03644	348
	1800	286TSC	87.5	1.00	230/460	MD4S30TSTSC61	LM03645	348
	1200	326TC	89.5	1.00	230/460	MD6S30TCTMC61	LM10730	502
	1200	326TSC	89.5	1.00	230/460	MD6S30TSTSC61	LM03866	502
40	1800	324TC	90.2	1.00	230/460	MD4S40TCTMC61	LM03674	440
	1800	324TSC	90.2	1.00	230/460	MD4S40TSTSC61	LM03675	440
	1200	364TC	91.7	1.00	230/460	MD6S40TCTMC61	LM03706	679
	1200	364TSC	91.7	1.00	230/460	MD6S40TSTSC61	LM03707	679
50	1800	326TC	91.7	1.00	230/460	MD4S50TCTMC61	LM03687	496
	1800	326TSC	91.7	1.00	230/460	MD4S50TST61Y	LM27884	496
	1200	365TC	91.7	1.00	230/460	MD6S50TCTMC61	LM03725	714
	1200	365TSC	91.7	1.00	230/460	MD6S50TSTSC61	LM03726	714
60	1800	364TC	92.4	1.00	230/460	MD4S60TCTMC61	LM03714	651
	1800	364TSC	92.4	1.00	230/460	MD4S60TSTSC61	LM03715	651
	1200	404TC	92.4	1.00	230/460	MD6S60TCTMC61	LM03787	887
	1200	404TSC	92.4	1.00	230/460	MD6S60TSTSC61	LM03788	887
75	1800	365TC	91.7	1.00	230/460	MD4S75TCTMC61	LM03735	721
	1800	365TSC	91.7	1.00	230/460	MD4S75TSTSC61	LM03736	721
	1200	405TC	92.4	1.00	230/460	MD6S75TCTMC61	LM03805	980
	1200	405TSC	92.4	1.00	230/460	MD6S75TSTSC61	LM03806	980
100	1800	404TC	93.0	1.00	230/460	MD4S100TCTMC61	LM10741	897
	1800	404TSC	93.0	1.00	230/460	MD4S100TSTSC61	LM03795	897
	1200	444TC	94.1	1.00	460	MD6S100TCTMC64PY	LM03757	1234
	1200	444TSC	94.1	1.00	460	MD6S100TSTSC64PY	LM03758	1234
125	1800	405TC	93.0	1.00	230/460	SE4S125TCTMC61	LM10744	1004
	1800	405TSC	93.0	1.00	230/460	MD4S125TSTSC61	LM03813	1004
	1200	445TC	94.1	1.00	460	MD6S125TCTMC64PY	LM10745	1419
	1200	445TSC	94.1	1.00	460	MD6S125TSTSC64PY	LM03771	1419
150	1800	444TC	93.6	1.00	460	MD4S150TCTMC64PY	LM10748	1272
	1800	444TSC	93.6	1.00	460	MD4S150TSTSC64PY	LM03764	1272
200	1800	445TC	94.5	1.00	460	MD4S200TCTMC64PY	LM10749	1482
	1800	445TSC	94.5	1.00	460	MD4S200TSTSC64PY	LM03777	1482
250	1800	445TC	93.6	1.00	460	MD4S250TCTMC64PY	LM10750	1600
	1800	445TSC	93.6	1.00	460	MD4S250TSTSC64PY	LM10751	1600

Product numbers in red are STOCK items.

Specifications are subject to change without notice