

Super Duck



LEESON Severe Duty, stainless frame, WASHGUARD II motors are designed for superior extended service in severe environments. Typical applications include food processing areas requiring frequent sanitation procedures using high pressure cleaning with concentrated caustic solutions, areas of high humidity and in chemical environments.

Mechanical Protection Features

These motors have an entirely paint free exterior with 300 series stainless steel motor body, conduit box lid, shaft extension, hardware, fasteners and an etched motor data plate.

To enhance chemical and corrosion resistance, all surfaces of the endbells and conduit box are processed using a U.S. Department of Agriculture approved technique. This proprietary process has been tested and qualified for more than 2,500 hours of salt spray endurance for external surfaces, and 1,000 hours for

internal surfaces. This process has proven successful in food washdown applications and has shown excellent corrosion resistance. Shaft seals, slingers and one-way stainless steel drains retard entrance of contaminants and water into the motor. Multiple, repositional drains provided for all angle mounting, release any water that does enter the motor from hose downs or condensation. Chemically resistant, tough nitrile gaskets and a threaded entrance for power connection also restrict entrance to the motor's interior. Nylon gaskets are used to seal bolt heads.

Bearings used are double sealed and prelubricated with moisture resistant Exxon POLYREX® EM high temperature lubricant.

Electrical Performance and Protection Features

Efficiencies meet EPACT mandates for covered motors when tested without shaft seals. High temperature, moisture resistant IRIS insulation system assures long life on inverter service. Windings are immersed and cured in polyester insulating compound. All Washdown Duty motors have Class F Insulation.

Standards and Approvals

UL component recognized, file number E57948, guide number PRGY2. Energy efficiency ratings are verified by an independent testing laboratory.

CSA Energy Efficiency Verification Program, report number EEV 78720-1.

Construction is CSA Certified for safety report number LR33543.

WASHGUARD II motors are certified to the Baking Industry Sanitation Standard #29 and listed under BISSC authorization number 769.



STAINLESS FRAME • TENV • C FACE LESS BASE

HP	SYN RPM 60 Hz	NEMA Frame	Catalog Number	App. Wgt. (lbs.)	Voltage	F.L. Amps 230V	% F.L. Eff.	"C" Dim. (Inches)
1/2	1800	56C	114394.00	30	208-230/460	1.6	78.5	11.06
3/4	1800	56C	114395.00	34	208-230/460	2.3	80.0	11.56
1	1800	56C	114437.00	44	208-230/460	3.0	81.5	12.06
	1800	143TC	121109.00	40	208-230/460	3.0	81.5	12.13
1 1/2	1800	56C	114581.00▶	45	208-230/460	4.4	84.0	12.69
	1800	145TC	G121350.00▶	45	208-230/460	4.4	82.5	13.25
2	1800	56C	114582.00▶	51	208-230/460	5.6	84.0	13.69
	1800	145TC	G121351.00▶	52	208-230/460	5.6	84.0	13.75

▶ All ratings TENV except 1/2 & 2 HP, which is TEFC with stainless steel fan cover and chemically inert fan.



STAINLESS FRAME • TENV • C FACE WITH BASE

HP	SYN RPM 60 Hz	NEMA Frame	Catalog Number	App. Wgt. (lbs.)	Voltage	F.L. Amps 230V	% F.L. Eff.	"C" Dim. (Inches)
1/2	1800	56HC	114560.00□	34	208-230/460	1.6	78.5	11.56
3/4	1800	56HC	114561.00□	38	208-230/460	2.3	80.0	12.06
1	1800	56HC	114562.00□	45	208-230/460	2.3	81.5	12.06
	1800	143TC	121165.00	45	208-230/460	2.3	81.5	12.13
1 1/2	1800	145TC	121912.00▶	47	208-230/460	4.4	86.5	13.25
	1800	145TC	121913.00▶	54	208-230/460	5.6	86.5	13.75

▶ All ratings TENV except 1/2 & 2 HP, which is TEFC with stainless steel fan cover and chemically inert fan.
 □ Combination 56H base motors have mounting holes for NEMA 56 and NEMA 143-145T and standard NEMA 56C face and shaft.

CHEMICAL RESISTANCE RATING CHART

CHEMICAL	CONCENTRATION	COMPONENT-RESISTANCE	
		STAINLESS STEEL PARTS	ENDBELLS & CONDUIT BOX
WATER:			
De-Ionized Boiling	100%	Excellent	Excellent
Salt (Immersed)	30%	Excellent	Excellent
Salt (Spray)	5%	Excellent	Excellent
Tap - 250°F/120°C @ 10,000 PSI	100%	Excellent	Excellent
ACIDS:			
Hydrochloric	35%	Poor	Very Good
Sulfuric	25%	Poor	Excellent
Nitric	35%	Excellent	Good
Picric	Saturated Solution	Excellent	Very Good
BASE:			
Caustic	100%	Excellent	Excellent
Caustic	12.5 pH	Excellent	Excellent
Caustic - 125°F/50°C	9.5 pH	Excellent	Excellent
SOLVENTS:			
	--	Excellent	Excellent



WATTSAVERe Motors Meet NEMA MG1 part 30 & 31.

Specifications are subject to change without notice

WASHGUARD SST



This member of LEESON's family of tough ducks is designed for long life in demanding washdown applications. LEESON's FHP WASHGUARD SST All-Stainless motors are Stainless Steel Tough!

Built with all stainless steel external components to prevent corrosion and well sealed against moisture and condensation to protect internal components, the Washguard SST all-stainless motors are able to withstand the severe wash-down environments found in the food processing, chemical processing, and beverage industries.



CHEMICAL RESISTANCE RATING CHART

CHEMICAL	CONCENTRATION	ALL STAINLESS COMPONENTS
WATER:		
De-Ionized Boiling	100%	Excellent
Salt (Immersed)	30%	Excellent
Salt (Spray)	5%	Excellent
Tap - 250°F/120°C @ 10,000 PSI	100%	Excellent
ACIDS:		
Hydrochloric	35%	Poor
Sulfuric	25%	Poor
Nitric	35%	Excellent
Picric	Saturated Solution	Excellent
BASE:		
Caustic	100%	Excellent
Caustic	12.5 pH	Excellent
Caustic - 125°F/50°C	9.5 pH	Excellent
SOLVENTS:		
	-	Excellent

300-Series stainless steel exterior components – frame, base, endshields, shaft extension, fan guard, hardware, conduit box and cover – for maximum corrosion resistance.

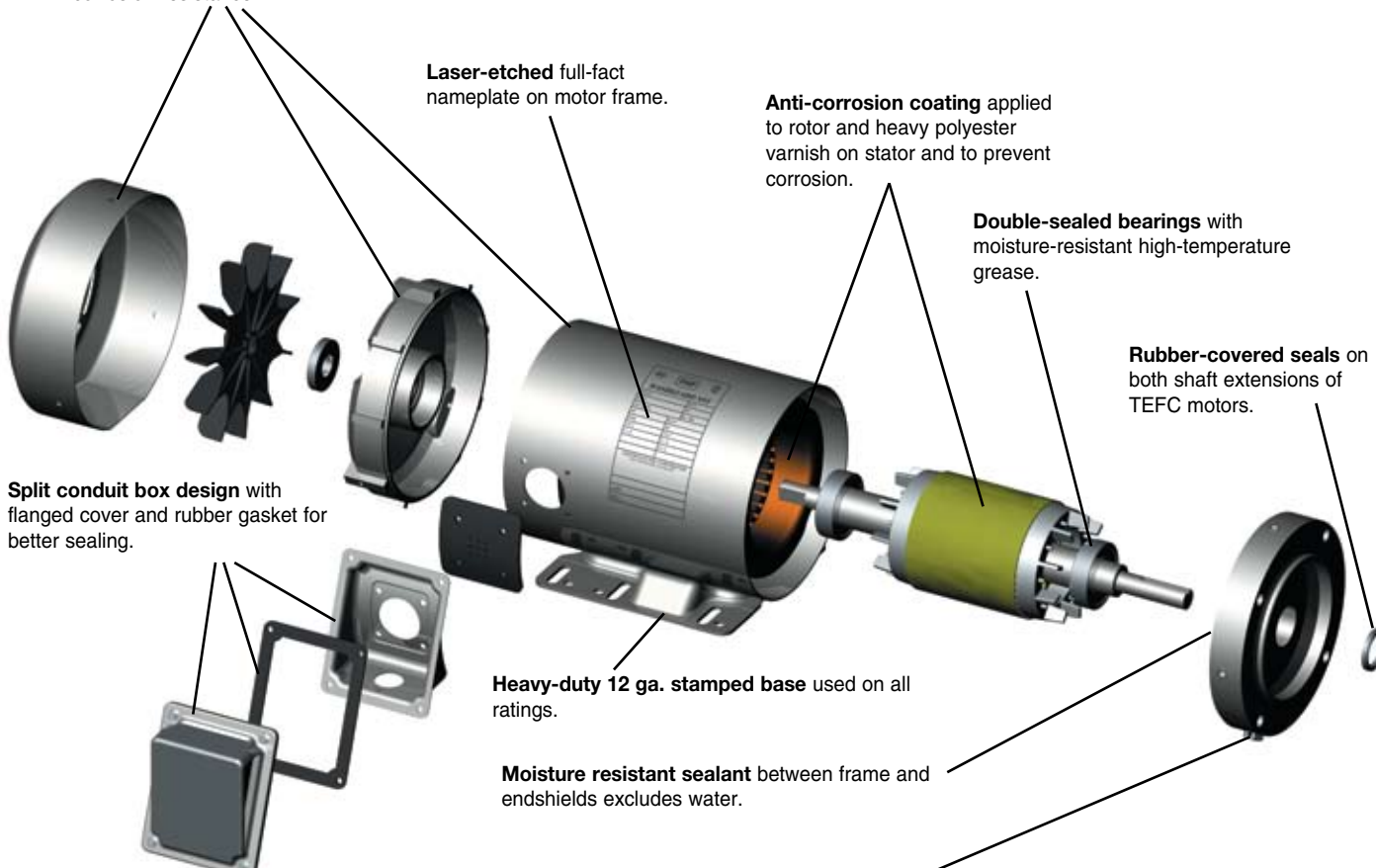

Four condensate drains in each endshield (at three, six, nine and twelve o'clock) provide locations to purge condensate and water, which may enter the motor.

T-drains provided for effective drainage without allowing water to splash inside the motor. T-drain for opposite shaft end is installed at six o'clock position (and can be relocated easily). T-drain for shaft end is shipped loose for customer installation at low point of motor.





WASHGUARD ALL-STAINLESS MOTORS

ALL-STAINLESS • SINGLE-PHASE & THREE-PHASE •
STANDARD, EPACT & NEMA PREMIUM RATINGS



WASHGUARD SST

Mechanical Protection Features:

All exterior components – frame, base, endshields, fan guard, shaft, hardware, conduit box and cover – are made from 300 series stainless steel for maximum corrosion resistance. Nameplate data is permanently laser-etched into the motor frame – no Mylar nameplate that can wash off or riveted metal nameplate to trap dirt. No paint or any type of coating is used on the exterior of the motor.

Sealant is applied to endshield and frame fits before assembly to prevent water entry. Shaft seals on both ends of TEFC motors – shaft end only on TENV. Double-sealed bearings have high performance Exxon Polyrex EM grease. Conduit box is fully gasketed half-split design with flanged cover and body gasket with lead separator. Anti-corrosion coating on rotor prevents corrosion. Four quadrant drain locations on each endbell allow drainage of condensation in any mounting position. Stainless steel T-drains are provided to prevent liquids from splashing into the drain locations. Motors are shipped with a T-drain assembled in the six o'clock position on the opposite endshield. Another T-drain is shipped loose in the conduit box for installation at the lowest point of the shaft-end endshield. For a totally sealed motor, a spare pipe plug is included to replace the pre-installed T-drain.

Mechanical performance is further enhanced by over-sized bearings, heavy 12 gauge base, shaft-end bearing is locked internally to limit axial endplay, and specially designed shaft extension resists breakage at bearing journal.

Electrical Performance and Protection Features:

FHP Washguard SST full load efficiencies meet EPACT standards for non-exempt motors when tested without shaft seals. For extra moisture resistance, windings are immersed and cured in polyester insulating varnish. LEESON's exclusive IRIS™ Inverter-Rated Insulation System provides extra protection and long life, especially in inverter driven applications.

10:1 Constant Torque Operation

Standards and Approvals:

UL component recognized, file number E57948, guide number PRGY2. Energy efficiency ratings are verified by an independent testing laboratory.

CSA Energy Efficiency Verification Program, report number EEV 78720-1.

Construction is CSA Certified for safety report number LR33543.

Motor is CE marked for European acceptance.



THREE-PHASE • TENV/TEFC • C FACE WITH BASE

HP	SYN RPM 60 Hz	NEMA Frame	Catalog Number	App. Wgt. (lbs.)	Voltage	F.L. Amps 230V	% F.L. Eff.	"C" Dim. (Inches)
1/3	3600	56C	191200.00●	29	208-230/460	1.0	74.0	9.78
	1800	56C	191201.00●	30	208-230/460	1.3	78.5	9.78
1/2	3600	56C	191203.00●	32	208-230/460	1.5	77.0	9.78
	1800	56C	191204.00●	33	208-230/460	1.6	81.5	9.78
	1200	56C	191414.00●	36	208-230/460	2.0	78.5	9.76
3/4	3600	56C	191206.00●	33	208-230/460	2.0	78.5	9.78
	1800	56C	191207.00●	38	208-230/460	2.3	82.5	9.78
	1200	56C	191415.00●	49	208-230/460	3.0	80.0	11.30
1	3600	56HC	191209.00□	41	208-230/460	2.6	80.0	13.77
	3600	143TC	191486.00	42	208-230/460	2.6	80.0	13.62
	1800	56C	191291.00●①	46	208-230/460	3.0	81.5	11.00
	1800	56HC	191211.00□	47	208-230/460	3.0	82.5	13.77
	1800	143TC	191487.00	48	208-230/460	3.0	85.5	13.62
	1200	56HC	191417.00	49	208-230/460	3.8	82.5	13.10
1200	145TC	191493.00	49	208-230/460	3.8	82.5	13.20	
1½	3600	56HC	191215.00□	48	208-230/460	3.8	82.5	13.77
	3600	143TC	191488.00	49	208-230/460	3.8	84.0	13.62
	1800	56HC	191217.00□	48	208-230/460	4.8	84.0	13.77
	1800	145TC	191489.00	49	208-230/460	4.8	86.5	13.62
2	3600	56HC	191221.00□	49	208-230/460	5.0	84.0	13.77
	3600	145TC	191490.00	50	208-230/460	5.0	85.5	13.62
	1800	56HC	191223.00□	52	208-230/460	5.8	84.0	13.77
	1800	145TC	191491.00	53	208-230/460	5.8	86.5	13.62
3	3600	145TC	191492.00	62	208-230/460	7.4	86.5	14.12

● These motors are totally enclosed, non-ventilated—Others are fan cooled.

□ Combination 56H base motors have mounting holes for NEMA 56 and NEMA 143-5T and a standard NEMA 56 shaft.

① 10:1 Constant Torque Operation



SINGLE-PHASE • TENV/TEFC • C FACE W/BASE

HP	SYN RPM	NEMA Frame	Catalog Number	App. Wgt. (lbs.)	Voltage	F.L. Amps 230V	"C" Dim. (Inches)
1/2	3600	56C	191474.00	29.5	115/208-230	3.1	11.1
	1800	56C	191475.00	31.5	115/208-230	4.1	11.1
3/4	3600	56C	191476.00	31.5	115/208-230	4.5	11.8
	1800	56C	191477.00	39.0	115/208-230	4.9	11.8
1	3600	56C	191478.00	39.0	115/208-230	6.2	12.3
	1800	56C	191479.00	42.5	115/208-230	6.8	12.3
1½	3600	56C	191480.00	42.5	115/208-230	8.8	13.2
	1800	56C	191481.00	52.5	115/208-230	9.5	13.2
2	3600	145TC	191482.00	64.5	115/208-230	10.8	14.2
	1800	145TC	191483.00	64.5	115/208-230	9.0	14.2

THREE-PHASE • TENV/TEFC • C FACE LESS BASE

HP	SYN RPM 60 Hz	NEMA Frame	Catalog Number	App. Wgt. (lbs.)	Voltage	F.L. Amps 230V	% F.L. Eff.	"C" Dim. (Inches)
1/3	1800	56C	191202.00●	30	208-230/460	1.3	78.5	9.78
1/2	1800	56C	191205.00●	33	208-230/460	1.6	81.5	9.78
	1200	56C	191419.00●	35	208-230/460	2.0	78.5	9.76
3/4	1800	56C	191208.00●	38	208-230/460	2.3	82.5	9.78
	1200	56C	191420.00●	47	208-230/460	3.0	80.0	11.30
1	1800	56C	191290.00●	45	208-230/460	3.0	81.5	11.00
	1800	56C	191213.00	47	208-230/460	3.0	82.5	13.77
	1800	143TC	G191214.00	47	208-230/460	3.0	82.5	13.62
1200	56C	191421.00	47	208-230/460	3.8	82.5	13.10	
1½	1800	56C	191219.00	48	208-230/460	4.8	84.0	13.77
	1800	145TC	G191220.00	48	208-230/460	4.8	84.0	13.62
2	1800	56C	191225.00	52	208-230/460	5.8	84.0	13.77
	1800	145TC	G191226.00	52	208-230/460	5.8	84.0	13.62

● These motors are totally enclosed, non-ventilated—Others are fan cooled.

WATTSaver Motors Meet NEMA MG1 part 30 & 31.

Catalog numbers in Green are EPACT Motors.

PREMIUM
STAINLESS STEEL DUCK



General Specifications:

Designed specifically to meet the demanding sanitation requirements of the pharmaceutical, food processing and beverage industries. These motors are also ideal in clean room and severe chemical-processing applications involving frequent washdown with nitric acid and caustic lye. In fact, WASHGUARD All-Stainless Motors include IEEE 841 severe-duty features right out of the box! Motors have been tested to and passed the IEC IP-56 test requirements.

Mechanical Protection Features:

- All exterior components are 300-series stainless steel.
- Nothing on the motor's exterior is painted or coated in any way.
- All sealing components are Viton® for superior chemical resistance.
- Full fact nameplate is laser etched on the motor frame – no separately attached nameplate to trap dirt or contaminants.
- Endshields are O-ring sealed to the frame.
- Double lip shaft seals on both ends of TEFC motors (shaft end only on TENV motors).
- Removable hydrophobic breathers in opposite shaft endbell and conduit box equalize pressure without allowing moisture to enter.
- Exterior fastener use minimized reducing the number of entry points for moisture. There are no holes in the frame for attaching a nameplate. Bearing lock screws are located inside the motor and the conduit box mounted screws have been eliminated.
- Double-sealed bearings are pre-lubricated with moisture-resistant high-temperature grease for long life.
- Interior coatings applied to rotor and stator protect against corrosion.
- New conduit box mounting system provides optimum sealing.
- Ease to clean construction is BISSC Certified for bakery applications..

Electrical Performance and Protection Features

- WASHGUARD efficiencies meet EPACT mandates for non-exempt motors when tested without shaft seals.
- Windings are immersed and cured in polyester insulating varnish for extra moisture-resistance.
- LEESON's exclusive IRIS™ Inverter-Rated Insulation System provides extra protection and long life, especially in inverter-driven applications.
- Single-phase motors use Solid State Sinpac® switch – no mechanical switch contacts to corrode and fail.
- All Washdown Duty motors have Class F Insulation.

Standards and Approvals

- Single and three phase motors are UL component recognized – file number E57948, guide number PRGY2.
- CSA Energy Efficiency Verification Program, report number EEV 78720-1.
- Construction is CSA Certified for safety report number LR33543 and listed under BISSC authorization number 769.

300-Series stainless steel exterior components – frame, base, endshields, shaft extension, fan guard, hardware, conduit box and cover – for maximum corrosion resistance.

CHEMICAL RESISTANCE RATING CHART

CHEMICAL	CONCENTRATION	ALL STAINLESS COMPONENTS
WATER:		
De-Ionized Boiling	100%	Excellent
Salt (Immersed)	30%	Excellent
Salt (Spray)	5%	Excellent
Tap - 250°F/120°C @ 10,000 PSI	100%	Excellent
ACIDS:		
Hydrochloric	35%	Poor
Sulfuric	25%	Poor
Nitric	35%	Excellent
Picric	Saturated Solution	Excellent
BASE:		
Caustic	100%	Excellent
Caustic	12.5 pH	Excellent
Caustic - 125°F/50°C	9.5 pH	Excellent
SOLVENTS:		
	-	Excellent

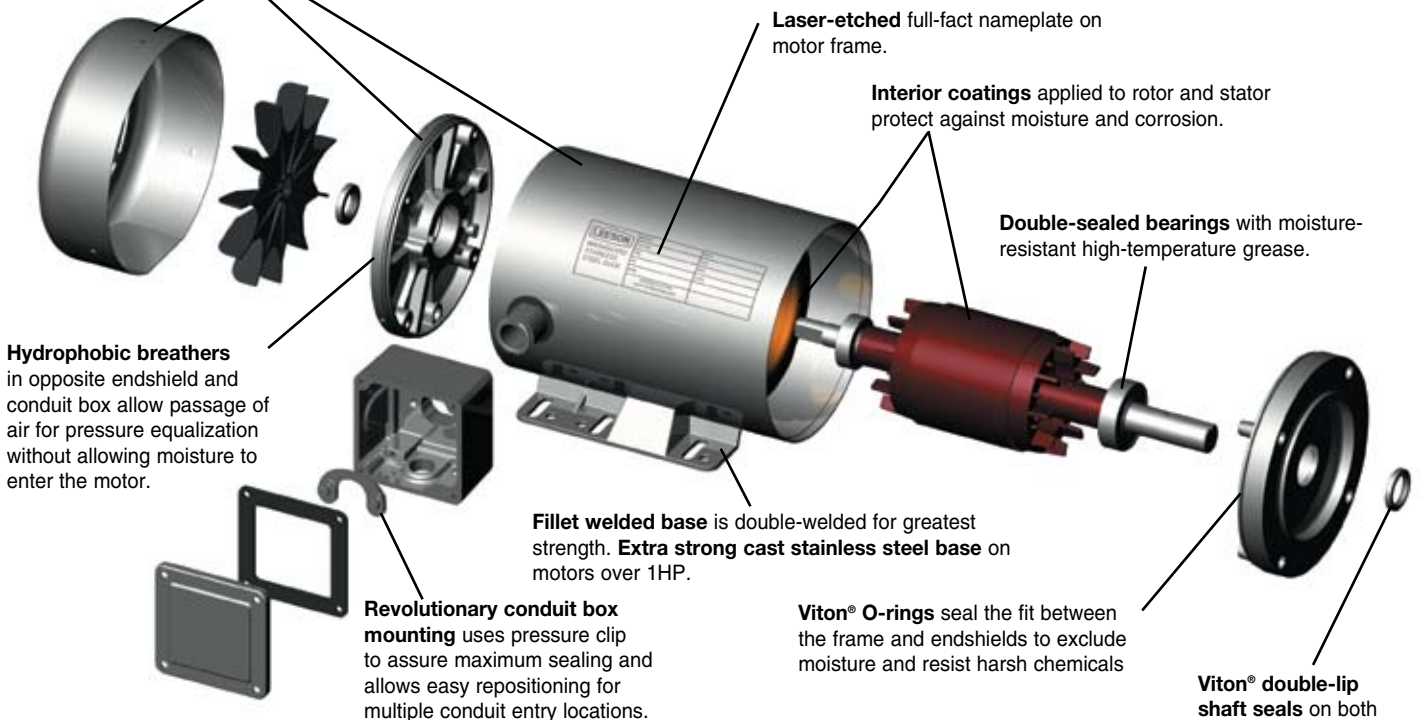

Specifications are subject to change without notice



PREMIUM
STAINLESS STEEL DUCK



THREE PHASE • TENV/TEFC • C FACE WITH BASE

HP	SYN RPM 60 Hz	NEMA Frame	Catalog Number	App. Wgt. (lbs.)	Voltage	F.L. Amps 230V	% F.L. Eff.	"C" Dim. (Inches)
1/2	3600	56HC	117269.00●	35	208-230/460	1.6	82.5	12.04
	1800	S56C	103387.00●	31	208-230/460	1.6	76.0	11.49
	1800	56HC	117266.00●	35	208-230/460	1.6	78.5	12.54
	1200	56HC	117275.00●	35	208-230/460	2.3	77.0	12.54
3/4	3600	56HC	117271.00●	40	208-230/460	2.4	84.0	12.54
	1800	S56C	103388.00	28	208-230/460	2.3	77.0	12.50
	1800	56HC	117267.00●	41	208-230/460	2.3	80.0	13.04
	1200	56HC	117276.00●	46	208-230/460	3.0	78.5	14.04
1	3600	56HC	117273.00●	43	208-230/460	2.6	85.5	13.04
	1800	56HC	115635.00●□	44	208-230/460	3.0	81.5	13.54
	1800	56HC	117286.00	39	208-230/460	3.1	82.5	13.13
	1800	143TC	121795.00●	44	208-230/460	3.0	81.5	13.61
	1800	143TC	121873.00	50	208-230/460	3.1	85.5	13.19
	1200	56HC	117277.00	48	208-230/460	4.0	77.0	13.13
1 1/2	3600	143TC	121874.00	45	208-230/460	4.0	84.0	13.69
	1800	56HC	117284.00	49	208-230/460	4.4	84.0	13.63
	1800	145TC	121875.00	49	208-230/460	4.4	86.5	13.69
	1200	56HC	117278.00	51	208-230/460	5.4	80.0	14.13
2	3600	145TC	121876.00	49	208-230/460	5.2	85.5	13.69
	1800	56HC	117285.00	50	208-230/460	5.6	84.0	13.63
	1800	145TC	121877.00	50	208-230/460	5.6	86.5	13.69
3	3600	145TC	121878.00	53	208-230/460	7.6	86.5	13.69
	1800	182TC	132206.00	85	208-230/460	8.2	89.5	14.77
5	3600	184TC	132207.00	90	208-230/460	12.0	88.5	14.77
	1800	184TC	132208.00	96	208-230/460	13.0	89.5	15.27
7 1/2	3600	213TC	140825.00	160	208-230/460	18.4	89.5	18.69
	1800	213TC	140826.00	160	208-230/460	20.4	91.7	18.69
10	3600	215TC	140827.00	165	208-230/460	24.0	90.2	18.69
	1800	215TC	140828.00	173	208-230/460	26.0	91.7	18.69

- These motors are totally enclosed, non-ventilated—Others are fan cooled.
- Combination 56H base motors have mounting holes for NEMA 56 and NEMA 143-5T and a standard NEMA 56 shaft.

THREE PHASE • TENV/TEFC • C FACE LESS BASE

HP	SYN RPM 60 Hz	NEMA Frame	Catalog Number	App. Wgt. (lbs.)	Voltage	F.L. Amps 230V	% F.L. Eff.	"C" Dim. (Inches)	
1/3	1800	48C	103393.00●	25	208-230/460	1.3	70.5	9.83	
	1/2	3600	56C	117279.00●	35	208-230/460	1.6	82.5	12.04
		1800	48C	103394.00●	27	208-230/460	1.6	76.0	11.58
		1800	S56C	103389.00●	30	208-230/460	1.6	76.0	11.49
3/4	1800	56C	117270.00●	34	208-230/460	1.6	78.5	12.54	
	3600	56C	117280.00●	40	208-230/460	2.4	84.0	12.54	
	1800	S56C	103390.00	33	208-230/460	2.3	77.0	12.50	
	1800	56C	117272.00●	40	208-230/460	2.3	80.0	13.04	
1	3600	56C	117281.00●	43	208-230/460	2.6	85.5	13.04	
	1800	56C	117274.00●	44	208-230/460	3.0	81.5	13.54	
	1800	56HC	117287.00	45	208-230/460	3.1	82.5	13.13	
	1800	143TC	121796.00●	44	208-230/460	3.0	81.5	13.61	
	1800	143TC	G121659.00	51	208-230/460	3.0	82.5	13.19	
	1 1/2	3600	143TC	G121560.00	52	208-230/460	4.0	82.5	13.69
2	1800	56C	117282.00	49	208-230/460	4.4	84.0	13.63	
	1800	145TC	G121525.00	55	208-230/460	5.2	84.0	13.69	
	3600	145TC	G121561.00	54	208-230/460	5.6	84.0	13.69	
3	1800	56C	117283.00	49	208-230/460	5.6	84.0	13.63	
	1800	145TC	G121527.00	60	208-230/460	5.6	84.0	13.69	
	3600	145TC	G121562.00	55	208-230/460	7.6	85.5	13.69	
5	1800	182TC	G131923.00	88	208-230/460	8.2	87.5	14.77	
	3600	184TC	G131949.00	98	208-230/460	12.0	87.5	14.77	
10	1800	184TC	G131924.00	102	208-230/460	13.0	87.5	15.27	

- These motors are totally enclosed, non-ventilated—Others are fan cooled.

Catalog Numbers in Green are EPACT Motors.

Specifications are subject to change without notice

SINGLE PHASE • TENV/TEFC • C FACE WITH BASE

HP	SYN RPM 60 Hz	NEMA Frame	Catalog Number	App. Wgt. (lbs.)	Voltage	Over-load Prot.	F.L. Amps 230V	"C" Dim. (Inches)
1/3	1800	56HC	116343.00●□	35	115/208-230	None	2.7	12.20
	3600	56HC	116344.00●□	38	115/208-230	None	3.8	12.20
1/2	1800	56HC	116345.00●□	38	115/208-230	None	3.3	12.70
	3600	56HC	116346.00●□	42	115/208-230	None	3.8	12.70
1	3600	56HC	116347.00●□	49	115/208-230	None	6.0	13.70
	1800	56HC	116348.00●□	49	115/208-230	None	4.5	13.70
1 1/2	3600	56HC	116482.00□	49	115/208-230	None	6.8	13.81
	1800	145TC	121622.00	53	115/208-230	None	7.4	14.81
2	3600	145TC	121623.00	57	115/208-230	None	8.8	14.81
	1800	145TC	121632.00	57	115/208-230	None	10.0	14.81

- These motors are totally enclosed, non-ventilated—Others are fan cooled.
- Combination 56H base motors have mounting holes for NEMA 56 and NEMA 143-5T and a standard NEMA 56 shaft.

SINGLE PHASE • TENV/TEFC • C FACE LESS BASE

HP	SYN RPM 60 Hz	NEMA Frame	Catalog Number	App. Wgt. (lbs.)	Voltage	Over-load Prot.	F.L. Amps 230V	"C" Dim. (Inches)
1/3	1800	56C	116349.00●	35	115/208-230	None	2.7	11.70
	3600	56C	116350.00●	38	115/208-230	None	3.3	12.70
3/4	1800	56C	116351.00●	42	115/208-230	None	3.8	12.70
	3600	56C	116352.00●	49	115/208-230	None	4.5	13.70
1 1/2	1800	145TC	121624.00	53	115/208-230	None	7.4	14.87
	3600	145TC	121633.00	57	115/208-230	None	10.0	14.87

- These motors are totally enclosed, non-ventilated—Others are fan cooled.



BRAKE MOTOR

THREE PHASE • TENV • C FACE WITH BASE

HP	SYM RPM 60 Hz	NEMA Frame	Brake Rating (ft-lbs)	Catalog Number	App. Wgt. (lbs.)	Voltage	F.L. Amps 230V	% F.L. Eff.	"C" Dim. (Inches)
1/2	1805	56C	3	116483.00●	59	208-230/460	1.6	78.5	15.85
	3600	56C	6	116484.00●	69	208-230/460	3.0	81.5	15.85

- These motors are totally enclosed, non-ventilated.

THREE PHASE • TEFC • JM PUMP

HP	SYN RPM 60 Hz	NEMA Frame	Catalog Number	App. Wgt. (lbs.)	Voltage	F.L. Amps 230V	% F.L. Eff.	"C" Dim. (Inches)
1	1800	143JM	G121626.00	55	208-230/460	3.0	82.5	16.00
	3600	143JM	G121627.00	55	208-230/460	4.0	82.4	16.00
1 1/2	1800	145JM	G121628.00	56	208-230/460	4.4	84.0	16.00
	3600	145JM	G121629.00	56	208-230/460	5.2	84.0	16.00
2	1800	145JM	G121630.00	57	208-230/460	5.6	84.0	16.50
	3600	145JM	G121631.00	57	208-230/460	7.6	85.5	16.50
3	1800	182JM	G131996.00	85	208-230/460	8.2	87.5	16.20
	3600	184JM	G131997.00	90	208-230/460	12.0	87.5	16.20
5	1800	184JM	G131998.00	96	208-230/460	13.0	87.5	16.77
	3600	213JM	G140740.00	160	208-230/460	18.4	88.5	16.81
7 1/2	1800	213JM	G140741.00	162	208-230/460	20.4	89.5	19.81
	3600	215JM	G140742.00	165	208-230/460	24.0	89.5	19.81
10	1800	215JM	G140743.00	173	208-230/460	26.0	89.5	19.81

WATTSAVERe Motors Meet NEMA MG1 part 30 & 31.



PREMIUM STAINLESS STEEL DUCK



IEC ALL-STAINLESS PREMIUM MOTORS

IEC B5 FLANGE - ROUND BODY

HP/ KW	SYN RPM	Frame	Catalog Number	App. Wgt. (lbs.)	Volts DC	F.L. Amps DC	% FL Eff.	"C" Dim. (Inches)
1/3-0.25	1800	71	103403.00●	30	208-230/460	1.3	70.5	9.87
	1800	80	103405.00●	30	208-230/460	1.3	70.5	9.87
1/2-0.37	1800	71	103404.00●	32	208-230/460	1.6	76.0	11.62
	1800	80	103406.00●	32	208-230/460	1.6	76.0	11.62
3/4-0.55	1800	80	103407.00	38	208-230/460	2.3	77.0	12.26
1- 0.75	1800	90	117516.00	45	208-230/460	3.1	82.5	13.13
1.5 - 1.1	1800	90	117517.00	49	208-230/460	4.4	84.0	13.63
2 - 1.5	1800	90	117518.00	49	208-230/460	5.6	84.0	13.63

IEC B5 FLANGE - RIGID BASE

HP/ KW	SYN RPM	Frame	Catalog Number	App. Wgt. (lbs.)	Volts DC	F.L. Amps DC	% FL Eff.	"C" Dim. (Inches)
1/3-0.25	1800	80	103408.00●	30	208-230/460	1.3	70.5	9.50
1/2-0.37	1800	80	103409.00●	32	208-230/460	1.6	76	12.75
3/4-0.55	1800	80	103410.00	38	208-230/460	2.3	77	12.26

IEC B14 FLANGE - ROUND BODY

HP/ KW	SYN RPM	Frame	Catalog Number	App. Wgt. (lbs.)	Volts DC	F.L. Amps DC	% FL Eff.	"C" Dim. (Inches)
1/3-0.25	1800	71	103395.00●	30	208-230/460	1.3	70.5	9.83
	1800	80	103397.00●	30	208-230/460	1.3	70.5	9.72
1/2-0.37	1800	71	103396.00●	32	208-230/460	1.6	76	11.58
	1800	80	103398.00●	32	208-230/460	1.6	76	11.582
3/4-0.55	1800	80	103399.00	38	208-230/460	2.3	77	12.48

IEC B14 FLANGE - RIGID BASE

HP/ KW	SYN RPM	Frame	Catalog Number	App. Wgt. (lbs.)	Volts DC	F.L. Amps DC	% FL Eff.	"C" Dim. (Inches)
1/3-0.25	1800	80	103400.00●	31	208-230/460	1.3	70.5	9.72
1/2-0.37	1800	80	103401.00●	33	208-230/460	1.6	76	11.58
3/4-0.55	1800	80	103402.00	39	208-230/460	2.3	77	12.48



EXTREME DUCK



General Specifications:

These Revolutionary Designed Stainless Steel Motors are built using our “Voice of the customer” design criteria to withstand extreme washdown and sanitation requirements of the food processing, pharmaceutical, packaging and beverage industries. Our Innovative Hydro Sealed System “HS™” protects from the “outside-in” by reducing entrance points of contaminants and eliminates the need for drain plugs and breathers. This proven process also minimizes exterior hardware, which may trap application elements. Our unique Rotor/Cartridge Seal System, “Q-CAR™” gives quick access to the interior of the motor should the need arise. 300-Series Stainless Steel used on all exterior surfaces gives ideal protection against severe chemical-processing applications and frequent washdown processes using Salt water, Nitric Acids and Solvents.

Mechanical Protection Features:

- All exterior components are 300-Series stainless steel
- Protech Bearing isolator used for the output shaft seal
- Double Lip Viton shaft seal used on non-drive output shaft on TEFC motors
- Minimal exterior fasteners due to no through-bolt design and screw on conduit box covers reduces surface areas that may trap contaminants
- Double-sealed bearings are pre-lubricated with moisture resistant, high temperature grease for long life
- Rotor/Cartridge, “Q-CAR™,” design for quick access to motor interior (patent pending).
- O-ring sealed openings on conduit box covers and Rotor/Cartridge cover
- Rigid Cast Base for rugged applications
- Conduit box lead hole location rotatable on TEFC designs
- Full fact nameplate is laser etched to the motor frame making frame surface smooth, which eliminates areas that trap contaminants
- Ease of clean construction is BISSC certified for bakery applications and motors meet Pharmaceutical Duty specifications
- IP 56 Enclosure protection

Electrical Performance and Protection Features

- Motors meet EPACT mandates for non-exempt motors when tested without shaft seals
- Total winding encapsulation using an Epoxy Resin.
- LEESON’s exclusive IRIS™ Inverter-Rated Insulation System provides extra protection and long life, especially when used in applications driven by an Inverter.
- 3 year warranty
- 10:1 constant torque operation

Standards and Approvals

- Motors are UL component recognized – file number E57948, guide number PRGY2
- CSA Energy Efficiency Verification Program, report number EEV 78720-1
- Construction is CSA Certified for safety, report number LR33543 and listed under BISSC authorization number 769
- 3 year warranty



CHEMICAL RESISTANCE RATING CHART

CHEMICAL	CONCENTRATION	ALL STAINLESS COMPONENTS
WATER:		
De-Ionized Boiling	100%	Excellent
Salt (Immersed)	30%	Excellent
Salt (Spray)	5%	Excellent
Tap - 250°F/120°C @ 10,000 PSI	100%	Excellent
ACIDS:		
Hydrochloric	35%	Poor
Sulfuric	25%	Poor
Nitric	35%	Excellent
Picric	Saturated Solution	Excellent
BASE:		
Caustic	100%	Excellent
Caustic	12.5 pH	Excellent
Caustic - 125°F/50°C	9.5 pH	Excellent
SOLVENTS:		
	-	Excellent

WASHGUARD ALL-STAINLESS MOTORS



ALL-STAINLESS • THREE PHASE • STANDARD & NEMA PREMIUM RATINGS



EXTREME DUCK



AC MOTORS

THREE PHASE • TENV/TEFC • C FACE WITH BASE

HP	SYN RPM 60 Hz	NEMA Frame	Catalog Number	App. Wgt. (lbs.)	Voltage	F.L. Amps 230V	"C" Dim. (Inches)
1/3
1/2	3600	56C	117118.00●	39	208-230/460	1.6	10.47

	1800	S56C	103411.00●	33	208-230/460	1.6	11.49
	1800	56C	117119.00●	40	208-230/460	1.6	10.72
3/4	3600	56C	117120.00●	46	208-230/460	2.4	10.47
	1800	S56C	103412.00	39	208-230/460	2.3	12.50
	1800	56C	117121.00●	47	208-230/460	2.3	11.22
1	3600	56C	117122.00●	48	208-230/460	2.6	10.97
	1800	56C	117123.00●	50	208-230/460	3.0	11.97
1½	3600	143TC	121879.00[w]	54	208-230/460	4.0	11.75
	3600	143TC	G121748.00	54	208-230/460	4.0	11.00
	1800	56C	117296.00	56	208-230/460	4.4	11.69
	1800	145TC	121880.00[w]	56	208-230/460	4.4	12.75
	1800	145TC	G121749.00	56	208-230/460	4.4	11.25
2	3600	145TC	121881.00[w]	56	208-230/460	5.2	12.75
	3600	145TC	G121739.00	56	208-230/460	5.2	12.50
	1800	56C	117299.00[w]	57	208-230/460	5.6	12.69
	1800	145TC	121882.00	57	208-230/460	5.6	13.25
	1800	145TC	G121740.00	57	208-230/460	5.6	12.50

THREE PHASE • TENV/TEFC • C FACE LESS BASE

HP	SYN RPM 60 Hz	NEMA Frame	Catalog Number	App. Wgt. (lbs.)	Voltage	F.L. Amps 230V	"C" Dim. (Inches)
1/3	1800	48C	103417.00●	30	208-230/460	1.3	9.58
1/2	3600	56C	117126.00●	38	208-230/460	1.6	10.47
	1800	48C	103418.00●	32	208-230/460	1.6	11.33
	1800	S56C	103413.00●	32	208-230/460	1.6	11.49
	1800	56C	117127.00●	39	208-230/460	1.6	10.72
3/4	3600	56C	117128.00●	45	208-230/460	2.4	10.47
	1800	S56C	103414.00	38	208-230/460	2.3	12.50
	1800	56C	117129.00●	46	208-230/460	2.3	11.22
1	3600	56C	117130.00●	47	208-230/460	2.6	10.97
	1800	56C	117131.00●	50	208-230/460	3.0	11.69
1½	3600	143TC	121908.00[w]	53	208-230/460	4.0	11.75
	3600	143TC	121750.00	53	208-230/460	4.0	11.00
	1800	56C	117297.00	55	208-230/460	4.4	11.69
	1800	145TC	121909.00[w]	55	208-230/460	4.4	12.75
	1800	145TC	121751.00	55	208-230/460	4.4	11.25
2	3600	145TC	121910.00[w]	55	208-230/460	5.2	12.75
	3600	145TC	121742.00	55	208-230/460	5.2	12.50
	1800	145TC	121743.00	56	208-230/460	5.6	12.50
	1800	145TC	121911.00[w]	56	208-230/460	5.6	13.25
	1800	56C	117298.00	56	208-230/460	5.6	12.69

● These motors are totally enclosed, non-ventilated—Others are fan cooled.
 [w] Premium efficiency WATSAVER[®] Motors. See page 19 for details.

● These motors are totally enclosed, non-ventilated—Others are fan cooled.
 [w] Premium efficiency WATSAVER[®] Motors. See page 19 for details.

Catalog numbers in green are EPACT motors.

