



SUB-FHP GEARMOTOR CONDUIT BOXES

Optional steel conduit or junction boxes are available. The boxes are painted and mount in holes using screws provided with all stock gearmotors.

Catalog Number	For Motor Frames	DIMENSIONS (Inches)			
		A	B	C	K
M1760000.00*	25	2.09	2.45	2.23	0.875
M1760021.00*	30/31	3.13	2.63	2.28	0.875
M1760007.00	34	3.13	2.63	2.28	0.875
M1760012.00	38	4.75	2.75	2.00	1.125
175893.00	42	4.75	2.75	2.00	1.125

Note: * For any gearmotor catalog number beginning with M1115XXX, must clarify from gearmotor type and frame columns as listed on catalog pages 164, 165 and 169. For example, if gearmotor type and frame lists P303-30E, then use 30 frame conduit box kit M1760021. If gearmotor type and frame lists 10F60-25, then use conduit box kit M1760000.

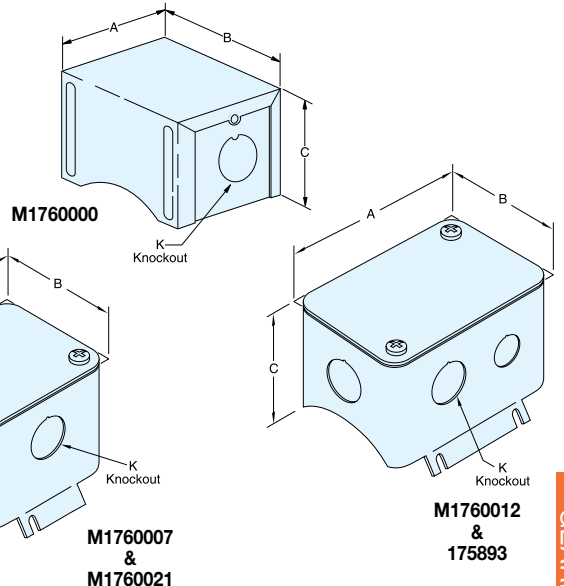

SUB-FHP GEARMOTOR "L" MOUNTING BRACKET

Optional "L" brackets can be used to mount parallel shaft type PZ or PE350 gearmotors. Of steel construction, they are painted and include screws for mounting to the motor, but not the application.

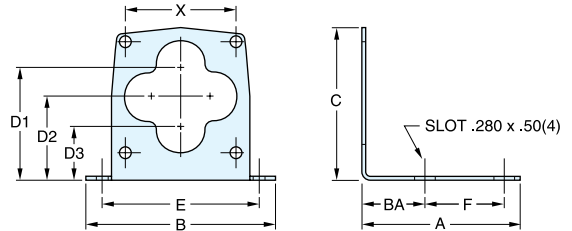

Catalog Number	For Motors	DIMENSIONS (Inches)									
		A	B	C	D ¹	D ²	D ³	X	BA	F	E
M1760003.00*	PZ Gearmotors	3.75	4.50	3.935	3.00	2.25	1.50	2.645	1.50	1.875	3.75
M1760011.00**	PE350 Gearmotors	4.50	6.00	5.520	4.00	3.10	2.20	3.625	1.50	2.500	5.00
M1760029.00Δ	PE350 Gearmotors	4.50	6.00	5.520	4.00	3.10	2.20	3.625	1.50	2.500	5.00

* Maximum radial load no greater than 50 lbs. This bracket can also be used on DC motors in the 34 frame having the style C mounting.
 ** Maximum radial load no greater than 200 lbs.
 Δ Washguard PE350 L-Bracket



SUB-FHP GEARMOTOR RIGHT-ANGLE BASE KIT

This Optional Base Kit can be used with the 10 Series right-angle gearmotors. (Includes screws for mounting to gearbox, but not the application.)

Catalog Number
M1760006

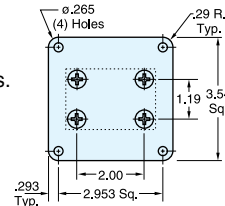

CAPACITORS FOR SUB-FHP RIGHT-ANGLE AC GEARMOTORS

MFD Rating	Voltage Rating	Catalog Number	W	DIMENSIONS (Inches)		
				H	T	D
10.0	250	003043.05	1.89	1.14	0.75	1.14
15.0	300	003042.05	2.28	1.61	1.14	2.48

CAPACITORS FOR SUB-FHP AC PZ SERIES GEARMOTORS

MFD Rating	Voltage Rating	Catalog Number	W	DIMENSIONS (Inches)		
				H	T	D
3.0	250	003043.01	1.22	0.93	0.57	0.97
10.0	250	003043.05	1.89	1.14	0.75	1.14

CAPACITORS FOR SUB-FHP P240 & PE350 AC GEARMOTORS

Gearmotor Type	MFD Rating	Voltage Rating	Catalog Number	W	DIMENSIONS (Inches)			
					H	T	D	
P240	7.5	250	003042.02	1.89	1.14	0.75	2.01	
PE350	10.0	250	003042.06	1.89	1.24	0.89	2.11	
P240	15.0	300	003042.05	2.28	1.61	1.14	2.48	
PE350	15.0	250	003042.04	2.28	1.46	0.93	2.33	

